

BSL722 COLD

Emergency LED Driver

PHILIPS bodine

A Division Of Philips Electronics North America Corporation

Up to 23.1 W emergency illumination with LEDs

Product Summary

UL COMPONENT RECOGNIZED/CSA CERTIFIED

Factory Installation Only
(Indoor and Damp Locations including
Sealed and Gasketed Fixtures)



Illumination Time

90 Minutes

Full Warranty

3 Years (NOT pro-rata)

Universal Input Voltage

120 through 277 VAC, 50/60 Hz

AC Input Current

260 mA

AC Input Power Rating

37 W

Output Voltage

28.0 to 33.0 VDC

Output Current

700 mA Nominal

Output Power

23.1 W (Maximum)

Test Switch

Optionally Provided

Battery

Two Field-Replaceable,
High-Temperature, Maintenance-Free
Nickel-Cadmium Batteries
7- to 10-Year Life Expectancy

Battery Charging Current

160 mA

Recharge Time

24 Hours

Charging Indicator Light

LED (Optionally Provided)

Temperature Rating (Ambient)

-20°C to +60°C
(-4°F to 140°F)

Dimensions

9.4" x 2.2" x 1.05"
(238 mm x 55.9 mm x 26.7 mm)
Mounting Center 8.9" (226 mm)

Weight

4.75 lbs. (2.12 kg)

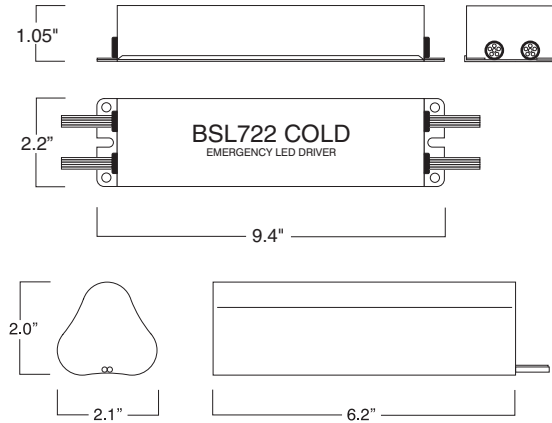

Application

The BSL722 COLD emergency LED driver works in conjunction with an AC LED driver to convert new or existing LED fixtures into emergency lighting. The emergency driver unit consists of a battery charger and electronic circuitry in one compact case. The batteries are separate from the driver and are field replaceable. The BSL722 COLD can be used with an LED lighting load of up to 23.1 Watts at rated current of 700 mA for 90 minutes. If used in an emergency-only fixture, no AC driver is necessary. The BSL722 COLD is suitable for damp locations as well as sealed and gasketed fixtures. The BSL722 COLD is not suitable for air handling heated air outlets or wet or hazardous locations. For more information about specific LED and AC driver compatibility, please call the factory.

Operation

When AC power fails, the BSL722 COLD immediately switches to the emergency mode, operating the LEDs for a minimum of 90 minutes. When AC power is restored, the emergency driver automatically returns to the charging mode.

Installation

The BSL722 COLD does not affect normal fixture operation and may be used with either a switched or unswitched fixture. If a switched fixture is used, an unswitched hot lead must be connected to the emergency driver. The emergency driver must be fed from the same branch circuit as the AC driver. Installation is not recommended with fixtures where the ambient temperature may fall below -20° C.

UL, and CODE COMPLIANCE

The BSL722 COLD has been tested by Underwriters Laboratories in accordance with the standards set forth in UL 924, "Emergency Lighting and Power Equipment," and by the Canadian Standards Association (CSA) in accordance with the standards set forth in C22.2 No. 141, "Unit Equipment for Emergency Lighting." The BSL722 COLD is UL Component Recognized and CSA Certified for factory installation only. Emergency illumination time exceeds the National Electrical Code (NEC), Life Safety Code (NFPA-LSC), National Building Code of Canada (NBC), National Fire Code of Canada (NFC) and UL 90-minute requirements.

Specifiers Reference

Project _____ Type _____ Model No. _____
Comments _____

L2300003

06/17/10 © Philips Emergency Lighting
P.O. Box 460 Collierville, TN USA 38027-0460
Sales 800-223-5728 FAX 901-853-5009
Tech. Support 888-263-4638
www.philips.com/bodine

BSL722 COLD

Emergency LED Driver

Up to 23.1 W emergency illumination with LEDs

Emergency Illumination

The BSL722 COLD operates an LED load of up to 23.1 W at rated current (700 mA Nominal) for a minimum of 90 minutes.

Specification

Emergency lighting shall be provided by using a standard LED fixture equipped with a Philips Bodine BSL722 COLD emergency driver. This emergency driver shall consist of two field-replaceable, high-temperature, maintenance-free nickel-cadmium batteries with a separate battery charger and electronic circuitry contained in one 9.4" x 2.2" x 1.05" metal case. Battery and installation hardware shall be provided and a test switch is optionally provided. The emergency driver shall be capable of operating an LED load of up to 23.1 Watts at rated current (700 mA) for a minimum of 90 minutes. It is suitable for damp locations as well as sealed and gasketed fixtures. The BSL722 COLD shall have 37 Watts of input power and a 54.0 Watt-hour battery capacity and shall comply with emergency standards set forth by the current NEC. The emergency driver shall be UL Component Recognized for factory installation only and shall be warranted for a full three years from date of purchase.

Warranty

Model BSL722 COLD is warranted for three (3) full years from date of purchase. This warranty covers only properly installed Philips Bodine emergency LED drivers used under normal conditions. For the warranty period, Philips Emergency Lighting will, at its option, repair or replace without charge a defective emergency LED driver, provided it is returned to the factory transportation prepaid and our inspection determines it to be defective under terms of the warranty. Repair or replacement, as stated above, shall constitute the purchaser's exclusive warranty, which does not extend to transportation, installation, labor or any other charges; nor does it apply to any equipment of another manufacturer used in conjunction with the emergency driver.

Typical Wiring Diagram

See Installation Instructions for complete information.

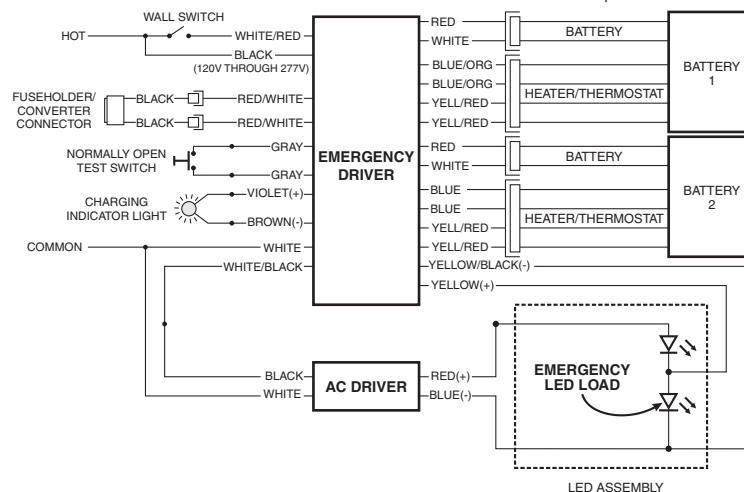

L2300003

06/17/10 © Philips Emergency Lighting
P.O. Box 460 Collierville, TN USA 38027-0460
Sales 800-223-5728 FAX 901-853-5009
Tech. Support 888-263-4638
www.philips.com/bodine

For the most current technical information and notices, please visit TechNotes on our website.