

GTD20A

Installation Instructions

EMERGENCY LIGHTING RELAY CONTROL DEVICE

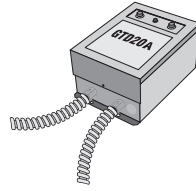

PHILIPS
bodine



! IMPORTANT SAFEGUARDS !

WHEN USING ELECTRICAL EQUIPMENT, BASIC SAFETY PRECAUTIONS SHOULD ALWAYS BE FOLLOWED, INCLUDING THE FOLLOWING:

READ AND FOLLOW ALL SAFETY INSTRUCTIONS

1. This product is for use with generator-supplied (or central inverter system-supplied) lighting loads. Make sure all connections are in accordance with the National Electrical Code and any local regulations.
2. To reduce the risk of electric shock, disconnect all power sources before servicing.
3. This product is for field installation.
4. This product is for use in indoor or damp locations.
5. An unswitched, normal AC power source (120 through 277 VAC, 50/60 Hz) and a direct, separate connection to a generator-supplied or central inverter system-supplied emergency panel are required.
6. The use of accessory equipment not recommended by the manufacturer may cause an unsafe condition.
7. Do not use this product for other than intended use.
8. Servicing should be performed by qualified service personnel.

SAVE THESE INSTRUCTIONS



CAUTION: THIS UNIT HAS MORE THAN ONE POWER SUPPLY CONNECTION POINT. TO REDUCE THE RISK OF ELECTRIC SHOCK, DISCONNECT ALL POWER SOURCES BEFORE INSTALLING OR SERVICING THIS UNIT.

SERVICE BY QUALIFIED PERSONNEL ONLY

NOTE: BEFORE INSTALLING THE CONTROL DEVICE, MAKE SURE THAT THE NECESSARY BRANCH CIRCUIT WIRING IS AVAILABLE. AN UNSWITCHED SOURCE OF NORMAL POWER IS REQUIRED. A SEPARATE CONNECTION TO A GENERATOR-SUPPLIED (OR CENTRAL INVERTER SYSTEM-SUPPLIED) CIRCUIT MUST ALSO BE PROVIDED.

03/30/12

© Philips Emergency Lighting

A Division of Philips Electronics North America Corporation

236 Mt. Pleasant Rd. • Collierville, TN 38017-2752 • Tech Support 888-263-4638 • Fax 901-854-1630 • www.philips.com/bodine
7010022

INSTALLATION



CAUTION: THIS UNIT HAS MORE THAN ONE POWER SUPPLY CONNECTION POINT. TO REDUCE THE RISK OF ELECTRIC SHOCK, DISCONNECT ALL POWER SOURCES BEFORE INSTALLING OR SERVICING THIS UNIT.

NOTE: BEFORE INSTALLING THE CONTROL DEVICE, MAKE SURE THAT THE NECESSARY BRANCH CIRCUIT WIRING IS AVAILABLE. AN UNSWITCHED SOURCE OF NORMAL POWER IS REQUIRED. A SEPARATE CONNECTION TO A GENERATOR-SUPPLIED (OR CENTRAL INVERTER SYSTEM-SUPPLIED) CIRCUIT MUST ALSO BE PROVIDED.

STEP #1 ► MOUNTING THE GTD20A

- > FAMILIARIZE YOURSELF WITH THESE INSTRUCTIONS BEFORE BEGINNING INSTALLATION.
- > Mount GTD20A in a convenient location using appropriate hardware (not supplied). See Illustration 1 for typical installation. **Do not mount with lid facing down.**

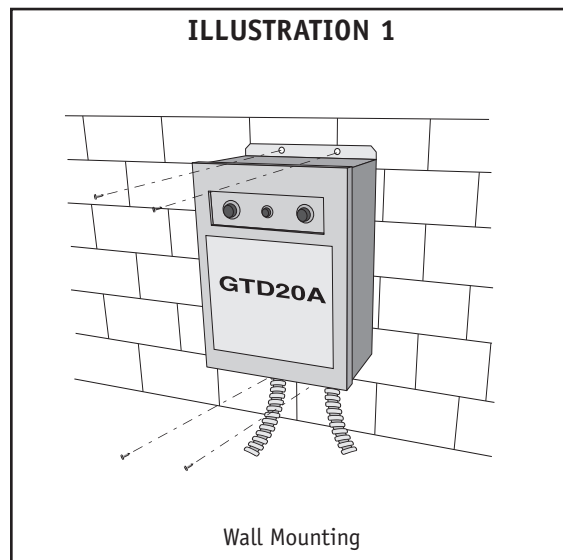

STEP #2 ► INSTALLING THE GTD20A

- > Disconnect AC power from all supply circuits.
- > Remove GTD20A lid and install necessary conduit and wiring (not supplied) to the GTD20A.
- > Refer to the illustrations on the following pages for proper wiring connections and choose the correct illustration for your application.
- > Note: When using Class 2 power limited circuits, (for example, 0-10 VDC dimming connections) remember to keep this wiring separate from high voltage wiring by using separate conduit and the enclosure knockout provided.
- > Replace GTD20A lid and secure.

INSTALLATION

ILLUSTRATION 2

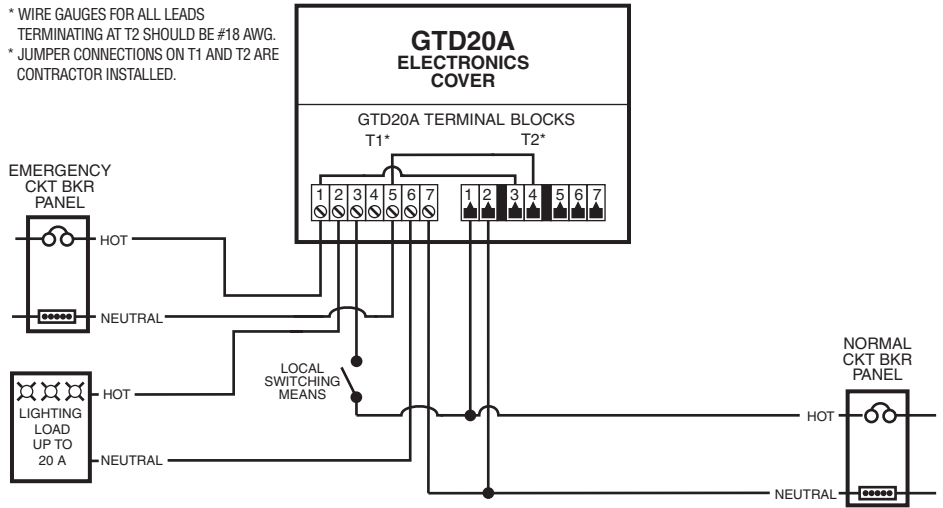

GTD20A as a Generator Transfer Device

ILLUSTRATION 3

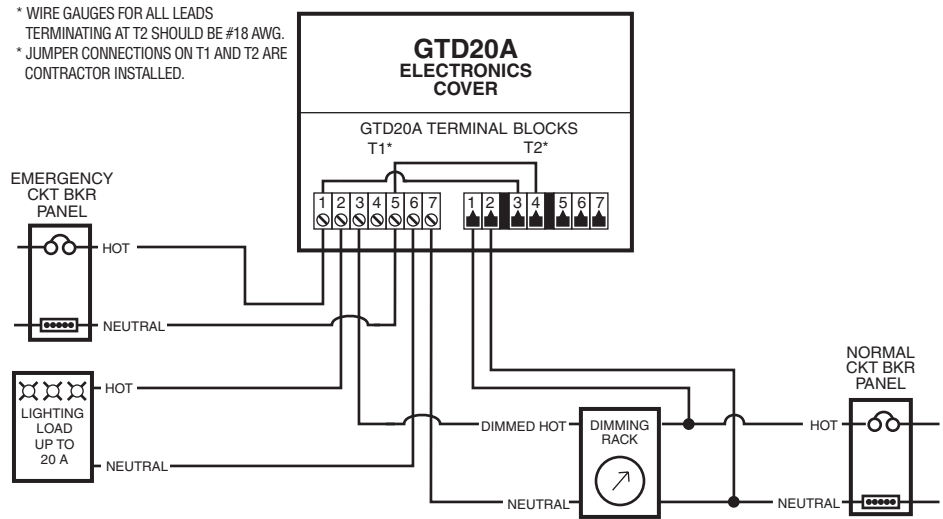

GTD20A as a Generator Transfer Device for a Dimming Rack

***NOTE:** Wire gauges for ALL leads terminating at T2 should be #18 AWG.
 Wire gauges for all other connections should be sized according to total connected lighting load.
 Ground unit using supplied green lead wire.

INSTALLATION

ILLUSTRATION 4

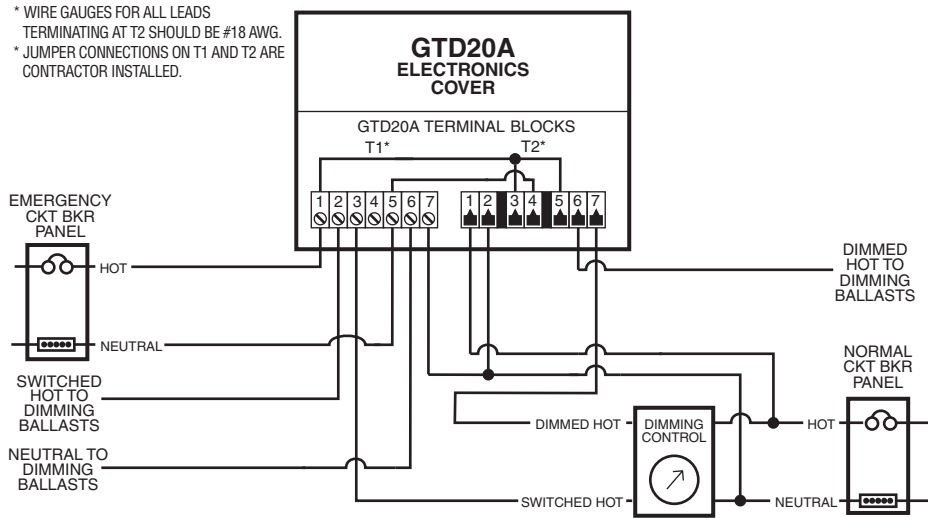

GTD20A as a Generator Transfer Device with a 3-wire Dimming System

ILLUSTRATION 5

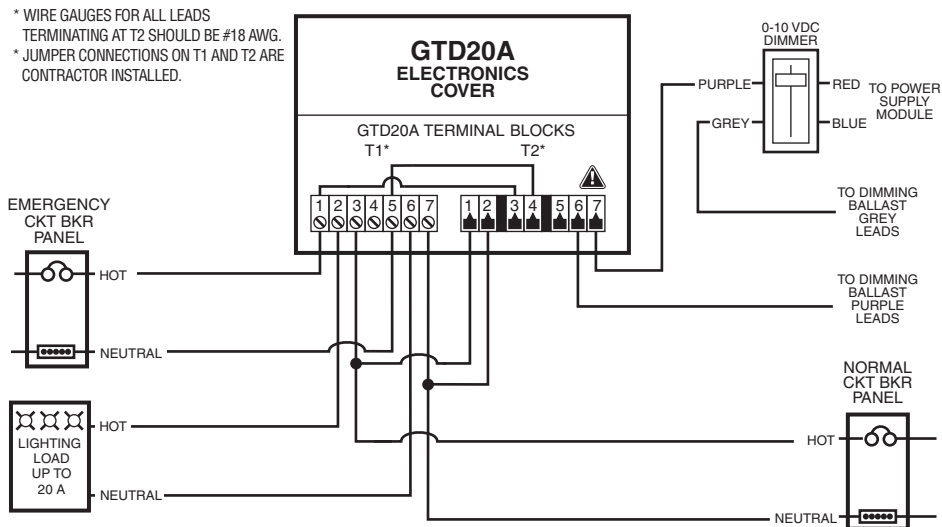

GTD20A as a Generator Transfer Device with a 0-10 VDC Dimming System



Use knockout provided on enclosure and separate conduit to route these wires (see Note in Step #2 on page 2).

***NOTE:** Wire gauges for ALL leads terminating at T2 should be #18 AWG. Wire gauges for all other connections should be sized according to total connected lighting load. Ground unit using supplied green lead wire.

INSTALLATION

ILLUSTRATION 6

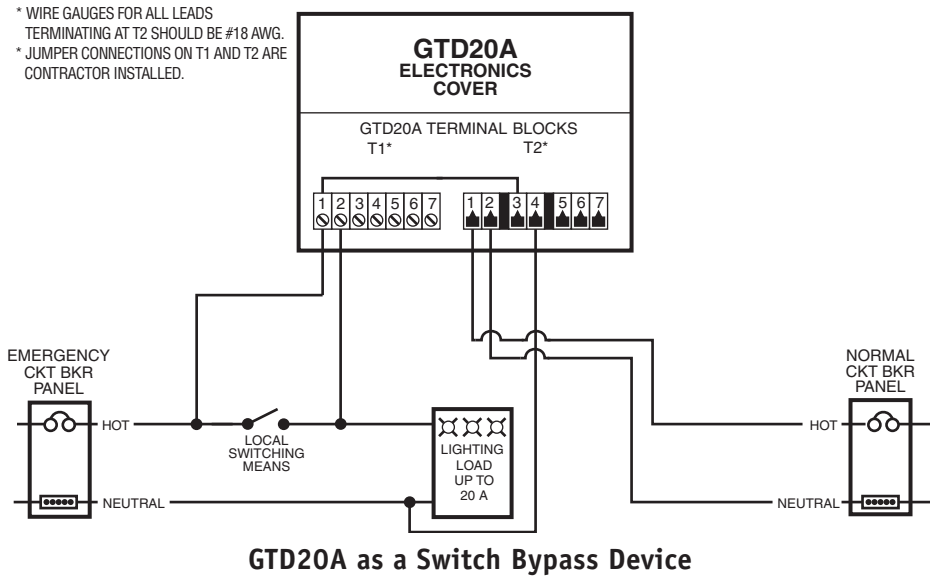
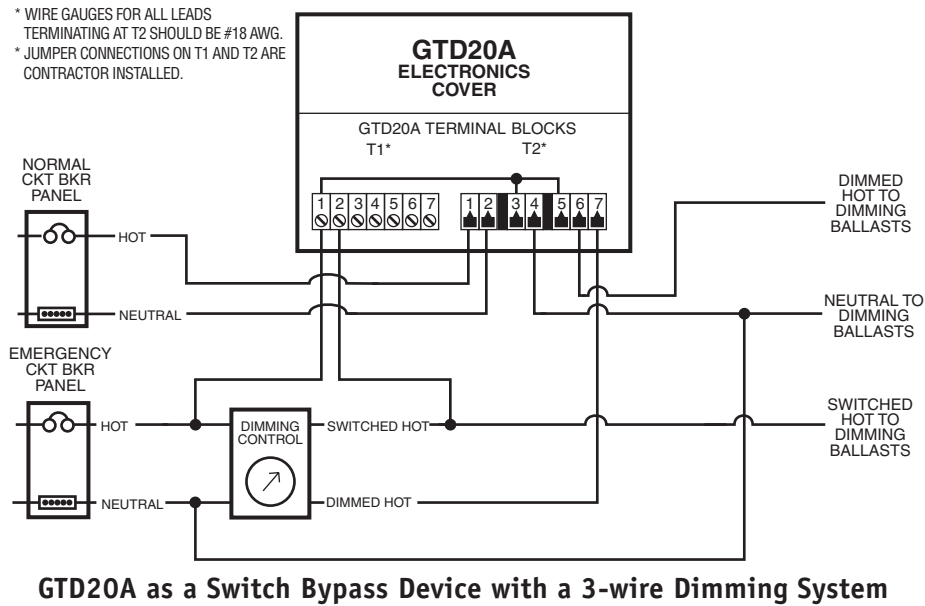

ILLUSTRATION 7



***NOTE:** Wire gauges for ALL leads terminating at T2 should be #18 AWG. Wire gauges for all other connections should be sized according to total connected lighting load. Ground unit using supplied green lead wire.

STEP #3



FOLLOW-UP & QUICK TEST OF THE INSTALLATION

- > Mark each designated emergency lighting fixture with the red dot labels provided.
- > Apply AC power to all circuits. The green "Normal Power Present" and the red "Emergency Power Available" LED's should be illuminated.
- > Perform a quick test as described on the unit label to check for proper operation. When the test button is depressed, the green "Normal Power Present" LED should extinguish and the controlled lighting load should illuminate regardless of the local switch position provided emergency power is available (check red LED).
- > During a quick test using a GTD20A with a dimming system, the lighting load should illuminate at full lumen levels when the test switch is depressed regardless of the lumen level during normal operation.
- > The entire generator (or central inverter) system, including all designated emergency loads, should be exercised to ensure proper operation (e.g., power up the generator, throw the transfer switch to the generator position, and check the emergency loads to verify they are operating properly from the generator supply).

OPERATION

The GTD20A uses an internal relay contact to control the AC power feeding the lighting load. When the generator (or central inverter) supplies AC power to the lighting fixture, the GTD20A bypasses the local switching means. This ensures the lighting load will be energized during generator (or central inverter) operation regardless of switch position.

MAINTENANCE

No routine maintenance is required to keep the GTD20A functional. However, it should be checked periodically to ensure that it is working properly. Note: Make sure to disconnect both the normal and emergency panel circuit breakers before servicing.

! REFER ANY SERVICING INDICATED BY THESE CHECKS TO QUALIFIED PERSONNEL !