

GEN3

Installation Instructions

FLUORESCENT BACKUP BALLAST

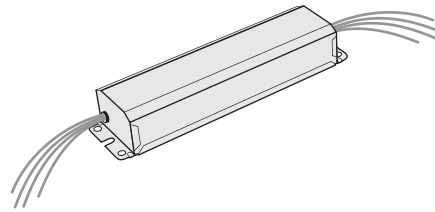

PHILIPS
bodine



! IMPORTANT SAFEGUARDS !

WHEN USING ELECTRICAL EQUIPMENT, BASIC SAFETY PRECAUTIONS SHOULD ALWAYS BE FOLLOWED, INCLUDING THE FOLLOWING:

READ AND FOLLOW ALL SAFETY INSTRUCTIONS

1. To prevent high voltage from being present on red, yellow, yellow/black, and yellow/red output leads prior to installation, inverter connector must be open. Do not join inverter connector until installation is complete and AC power is supplied to the backup ballast.
2. This product is for use with most two or three 32 W (4') T8 fluorescent lamps, or two 40 W to 55 W (4-pin) long compact fluorescent lamps without integral starters.
3. Make sure all connections are in accordance with the National Electrical Code and any local regulations.
4. To reduce the risk of electric shock, disconnect both normal and emergency power supplies and inverter connector of the backup ballast before servicing.
5. This backup ballast is for factory or field installation in either the ballast channel or on top of the fixture.
6. This product is for use in indoor fixtures except air handling heated air outlets, and wet, damp, or hazardous locations.
7. An AC power source (120 or 277 VAC, 60 Hz) ahead of any wall switch is required to provide battery charging current.
8. Do not install near gas or electric heaters.
9. Do not attempt to service the battery. A sealed, no-maintenance battery is used that is not field replaceable. Contact the manufacturer for information on service.
10. The use of accessory equipment not recommended by the manufacturer may cause an unsafe condition.
11. Do not use this product for other than intended use.
12. Servicing should be performed by qualified service personnel.

SAVE THESE INSTRUCTIONS



Ni - Cd

**THIS PRODUCT CONTAINS A RECHARGEABLE NICKEL-CADMIUM BATTERY.
THE BATTERY MUST BE RECYCLED OR DISPOSED OF PROPERLY.**

11/17/10

© Philips Emergency Lighting

A Division of Philips Electronics North America Corporation

236 Mt. Pleasant Rd. • Collierville, TN USA 38017-2752 • Tech Support 888-263-4638 • Fax 901-854-1630 • www.philips.com/bodine
70800002

INSTALLATION



WARNING: TO PREVENT HIGH VOLTAGE FROM BEING PRESENT ON RED, YELLOW, YELLOW/BLACK, AND YELLOW/RED OUTPUT LEADS PRIOR TO INSTALLATION, INVERTER CONNECTOR MUST BE OPEN. DO NOT JOIN INVERTER CONNECTOR UNTIL INSTALLATION IS COMPLETE AND AC POWER IS SUPPLIED TO THE BACKUP BALLAST.

NOTE: Make sure that the necessary branch circuit wiring is available. An unswitched source of power is required. The backup ballast must be fed from the same branch circuit as the AC ballast.

STEP #1 INSTALLING THE BACKUP BALLAST

- > Disconnect AC power from the fixture. Remove the ballast channel cover and install the backup ballast either in the ballast channel or on top of the fixture.*
- > Depending on the type of fixture in use install backup ballast using one of the methods illustrated below.

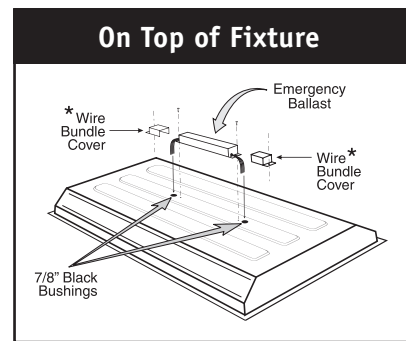
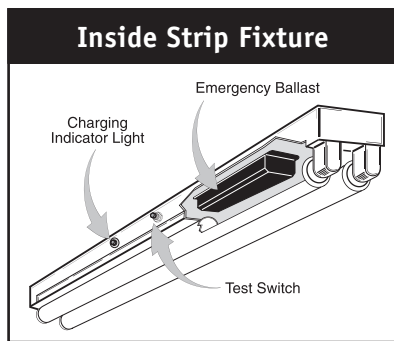
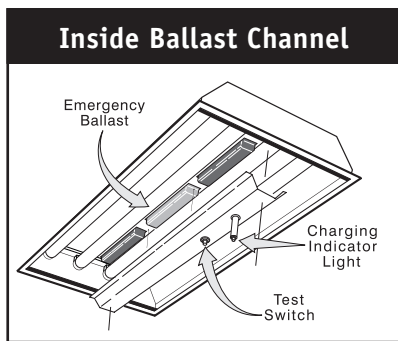

* For installation on top of the fixture, wire bundle covers (RMC-60) may be required by state or local codes. These covers are available from the manufacturer as an accessory kit and must be ordered separately. Call your local distributor or the factory for complete information.

STEP #2 INSTALLING THE TEST SWITCH

- > Refer to the illustrations above and install the test switch through the ballast channel cover of a troffer or through the side of a strip fixture.
- > Drill a 1/2" hole and install the switch as shown.
- > Refer to the diagrams below and wire the test switch so that it removes AC power from both the backup ballast and the AC ballast at the same time.

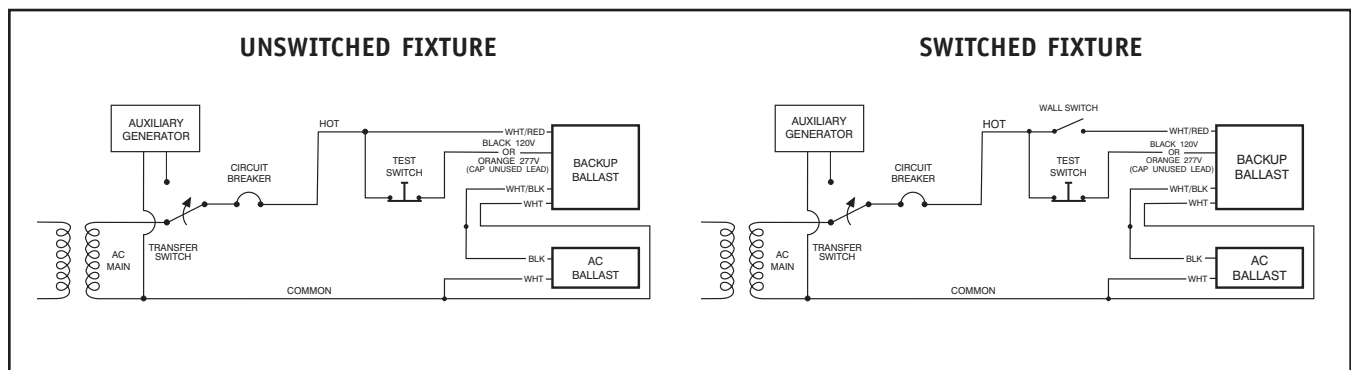
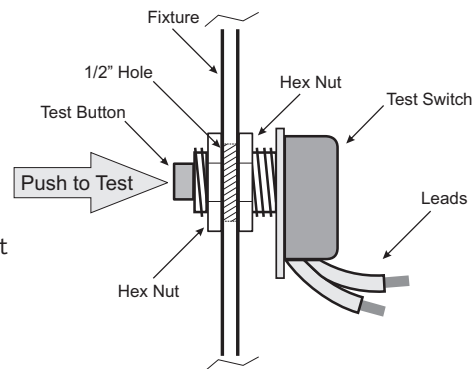

STEP #3 ▶ INSTALLING THE CHARGING INDICATOR LIGHT

- > Install the CHARGING INDICATOR LIGHT as shown in the illustration below so that it will be visible after the fixture is installed.

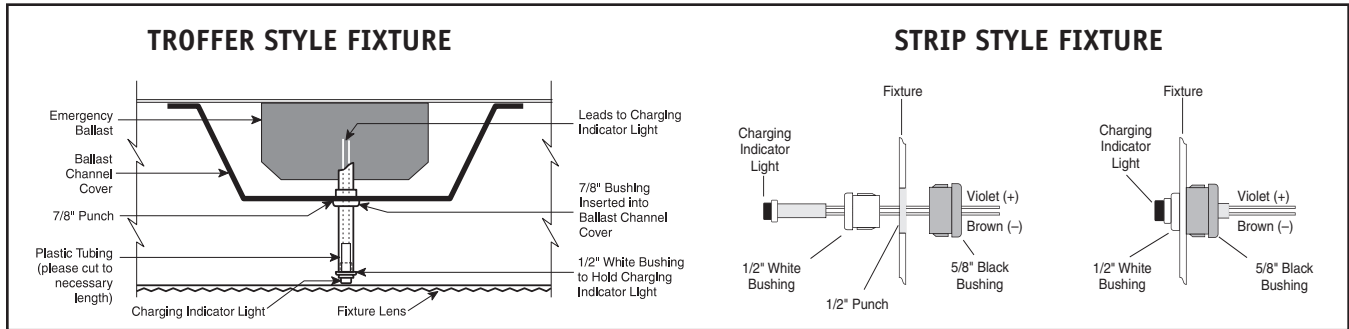

NOTE: After installing the charging indicator light and test switch, mark each with the appropriate label.

STEP #4 ▶ WIRING THE BACKUP BALLAST

- > Determine the type of AC ballast installed in the fixture.
- > Select the appropriate wiring diagram on back page to connect the backup ballast to the AC ballast and lamp(s). Make sure all connections are in accordance with the National Electrical Code and any local regulations.
- > To disable audible alarm, cut the red/white wire loop and cap the loose ends.
- > After installation is complete, supply AC power to the backup ballast and join the inverter connector.
- > At this point, power should be connected to both the AC ballast and the backup ballast, and the Charging Indicator Light should illuminate indicating the battery is charging.
- > A short-term discharge test may be conducted after the backup ballast has been charging for two hours. Charge for 24 hours before conducting a long-term discharge test. Refer to OPERATION.
- > In a readily visible location, attach the label **"CAUTION - This Unit Has More Than One Power Connection Point. To Reduce The Risk Of Electric Shock, Disconnect Both The Branch Circuit-Breakers Or Fuses And Emergency Power Supplies Before Servicing."**

OPERATION

When AC power is applied, the charging indicator light is illuminated, indicating that the battery is being charged. When power fails, the backup ballast automatically switches to battery power, operating two or three lamps at high illumination for at least two minutes. If enabled, the audible alarm will sound during emergency operation.

MAINTENANCE

Although no routine maintenance is required to keep the backup ballast functional, it should be checked periodically to ensure that it is working. The following schedule is recommended:

1. Visually inspect the charging indicator light monthly. It should be illuminated.
2. Test the backup operation of the fixture at 30-day intervals for a minimum of 20 seconds. Two or three lamps should operate at high illumination and an audible alarm will sound if enabled.
3. Conduct a 2-minute discharge test once a year. Two or three lamps should operate at high illumination for at least two minutes.

! REFER ANY SERVICING INDICATED BY THESE CHECKS TO QUALIFIED PERSONNEL !

BACKUP BALLAST AND AC BALLAST MUST BE FED FROM THE SAME BRANCH CIRCUIT
 TYPICAL SCHEMATICS ONLY. MAY BE USED WITH OTHER BALLASTS. CONSULT THE FACTORY FOR OTHER WIRING DIAGRAMS.

WIRING DIAGRAMS FOR 3-LAMP BACKUP OPERATION

FIG A THREE (3) LAMP INSTANT START PARALLEL BALLAST

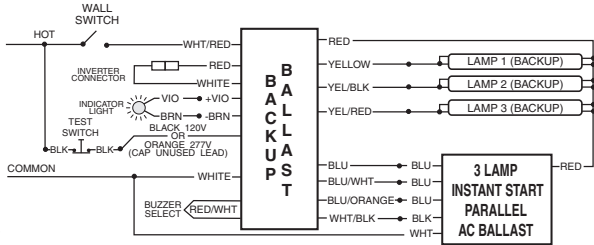
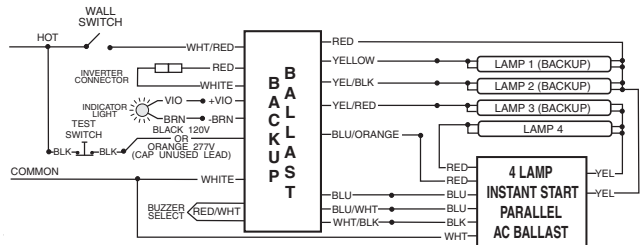

FIG B FOUR (4) LAMP INSTANT START PARALLEL BALLAST



BACKUP BALLAST AND AC BALLAST MUST BE FED FROM THE SAME BRANCH CIRCUIT
 TYPICAL SCHEMATICS ONLY. MAY BE USED WITH OTHER BALLASTS. CONSULT THE FACTORY FOR OTHER WIRING DIAGRAMS.

WIRING DIAGRAMS FOR 2-LAMP BACKUP OPERATION

FIG C TWO (2) LAMP INSTANT START PARALLEL BALLAST

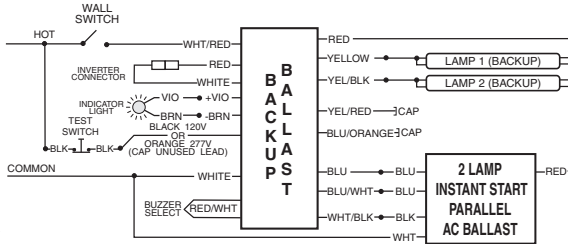

FIG D TWO (2) LONG COMPACT LAMP INSTANT START PARALLEL BALLAST

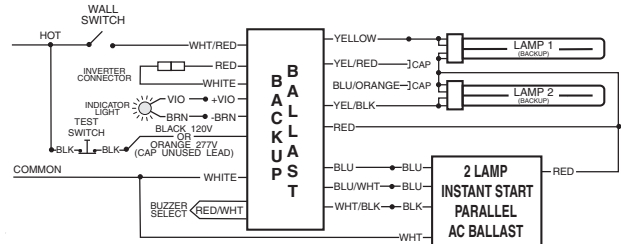

FIG E THREE (3) LAMP INSTANT START PARALLEL BALLAST

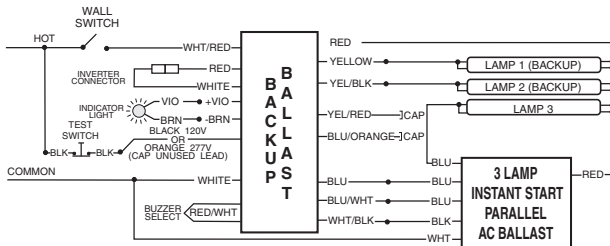

FIG F FOUR (4) LAMP INSTANT START PARALLEL BALLAST

