

# BSL17C-C2

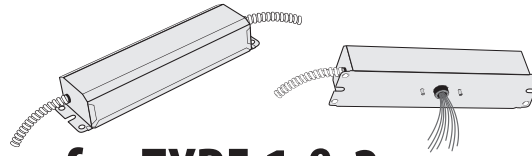

**PHILIPS**  
**bodine**

## Installation Instructions for TYPE 1 & 2

EMERGENCY LED DRIVER



### **! IMPORTANT SAFEGUARDS !**

**WHEN USING ELECTRICAL EQUIPMENT, BASIC SAFETY PRECAUTIONS SHOULD ALWAYS BE FOLLOWED, INCLUDING THE FOLLOWING:**

## READ AND FOLLOW ALL SAFETY INSTRUCTIONS

1. To prevent high voltage from being present on yellow & yellow/black output leads prior to installation, converter connector must be open. Do not join converter connector until installation is complete and AC power is supplied to the emergency driver.
2. This product is for use with an emergency LED lighting load and supplies up to 7.0 W of power (measured at nominal battery voltage) at a maximum rated current of 270 mA with a maximum voltage of 50 VDC in emergency mode for a minimum of 90 minutes.
3. Make sure all connections are in accordance with the National Electrical Code or Canadian Electrical Code and any local regulations.
4. To reduce the risk of electric shock, disconnect both normal and emergency power supplies and converter connector of the emergency driver before servicing.
5. This emergency driver is for factory installation only.
6. This product is suitable for use in damp locations where the ambient temperature is 0°C minimum, +50°C maximum. Product is not suitable for heated air outlets and wet or hazardous locations.
7. An unswitched AC power source is required (120 or 277 VAC, 60 Hz).
8. Do not install near gas or electric heaters.
9. Do not attempt to service the battery. A sealed, no-maintenance battery is used that is not field replaceable. Contact the manufacturer for information on service.
10. The use of accessory equipment not recommended by the manufacturer may cause an unsafe condition.
11. Do not use this product for other than intended use.
12. Servicing should be performed by qualified service personnel.

### **SAVE THESE INSTRUCTIONS**



Ni - Cd

**THIS PRODUCT CONTAINS A RECHARGEABLE NICKEL-CADMIUM BATTERY.  
THE BATTERY MUST BE RECYCLED OR DISPOSED OF PROPERLY.**

09/23/11

© Philips Emergency Lighting

A Division of Philips Electronics North America Corporation

236 Mt. Pleasant Rd. • Collierville, TN USA 38017-2752 • Tech Support 888-263-4638 • Fax 901-854-1630 • [www.philips.com/bodine](http://www.philips.com/bodine)  
70100209



**WARNING: TO PREVENT HIGH VOLTAGE FROM BEING PRESENT ON YELLOW & YELLOW/BLACK OUTPUT LEADS PRIOR TO INSTALLATION, CONVERTER CONNECTOR MUST BE OPEN. DO NOT JOIN CONVERTER CONNECTOR UNTIL INSTALLATION IS COMPLETE AND AC POWER IS SUPPLIED TO THE EMERGENCY DRIVER.**

**NOTE:** Make sure the necessary branch circuit wiring is available. An unswitched source of power is required. The emergency driver must be fed from the same branch circuit as the AC driver.

## EMERGENCY DRIVER AND AC DRIVER MUST BE FED FROM THE SAME BRANCH CIRCUIT

TYPICAL SCHEMATICS ONLY. MAY BE USED WITH OTHER DRIVERS. CONSULT THE FACTORY FOR OTHER WIRING DIAGRAMS.

### WIRING DIAGRAMS

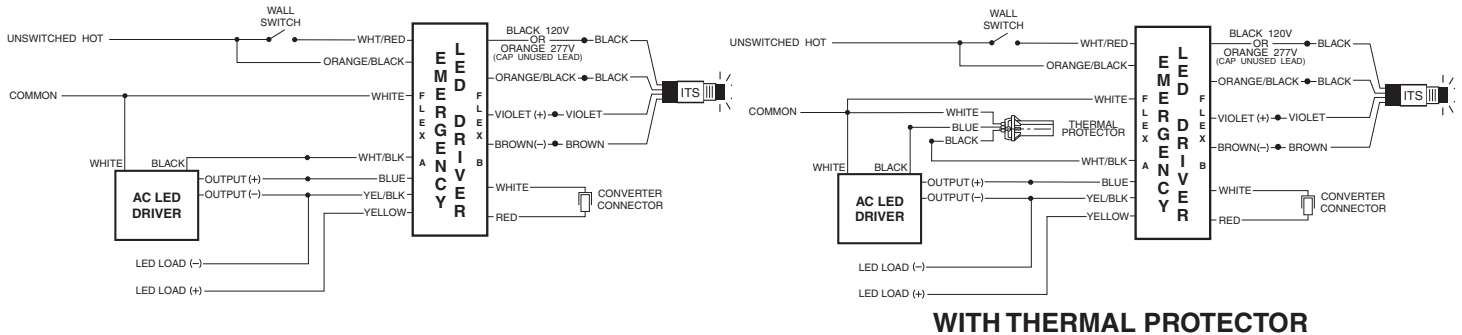

### WIRING DIAGRAMS FOR FIXTURES WITH THE FORTIMO DLM & DRIVER

**TABLE 1. UL CLASSIFIED LOADS**

Fortimo DLM and SLM Series, Load Reference	RATED WATTAGE (W)	QTY OF LEADS IN ARRAY	LED PART NO. OR TYPE OF LED
Fortimo LED DLM1100 19W/830UL	19	10 or 14	LXML-PRO1, Color bin 5 average
Fortimo LED DLM1100 18W/835UL	18	10	LXML-PRO1, Color bin 5 average
Fortimo LED DLM1100 17W/840UL	17	10 or 14	LXML-PRO1, Color bin 5 average
Fortimo LED DLM2000 36W/830UL	36	14	LXML-PRO1, Color bin 5 average
Fortimo LED DLM2000 34W/835UL	34	14	LXML-PRO1, Color bin 5 average
Fortimo LED DLM2000 33W/840UL	33	14	LXML-PRO1, Color bin 5 average
Fortimo LED SLM1100 18W/830	18	9	LUXEON Rebel LXM3-PW71
Fortimo LED SLM1100 18W/835	18	9	LUXEON Rebel LXM3-PW61
Fortimo LED SLM1100 17W/840	17	9	LUXEON Rebel LXM3-PW51
Fortimo LED SLM2000 33W/830	33	16	LUXEON Rebel LXM3-PW71
Fortimo LED SLM2000 33W/835	33	16	LUXEON Rebel LXM3-PW61
Fortimo LED SLM2000 31W/840	31	16	LUXEON Rebel LXM3-PW51

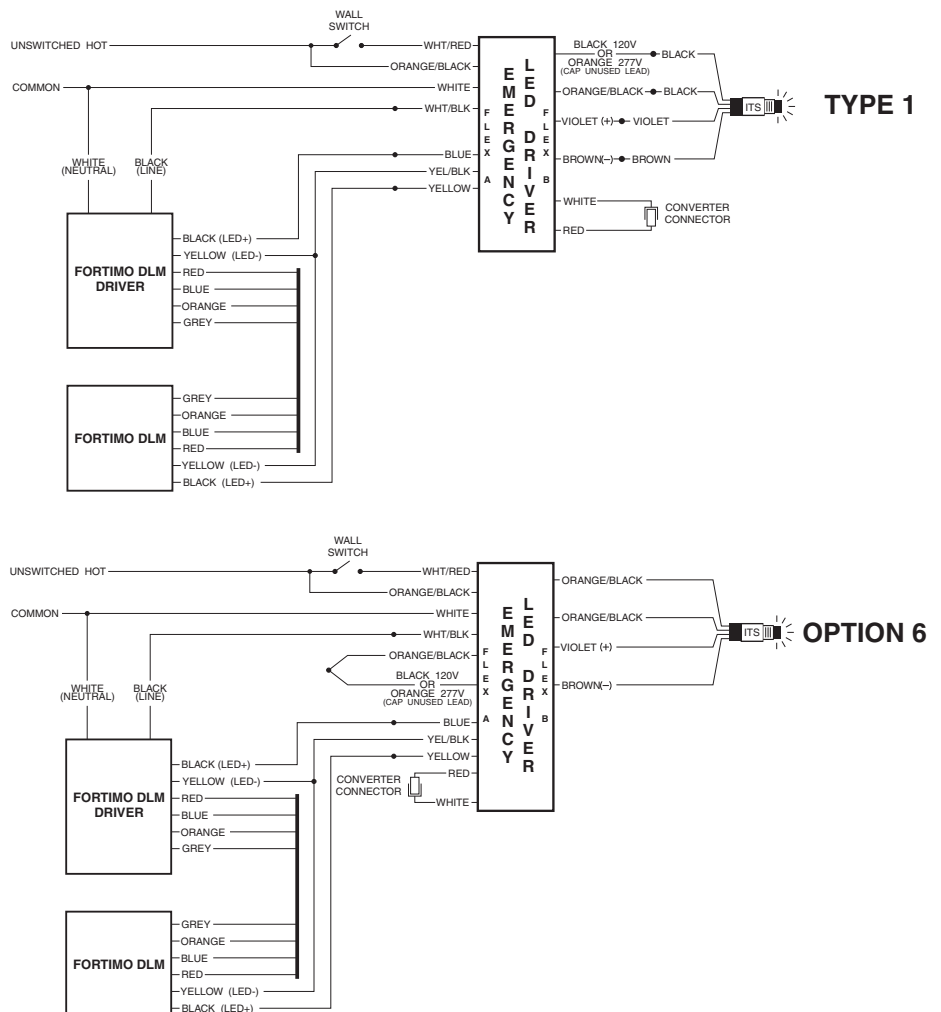

**NOTE:**

For Type 2 units, Flex A is not provided. The wires exit through the opening near the studs on the bottom of the unit.