

BLCD-20B

PHILIPS
bodine

Installation Instructions

EMERGENCY LIGHTING CONTROL UNIT

FOR GENERATOR OR CENTRAL INVERTER SUPPLIED LIGHTING



! IMPORTANT SAFEGUARDS !

WHEN USING ELECTRICAL EQUIPMENT, BASIC SAFETY PRECAUTIONS SHOULD ALWAYS BE FOLLOWED, INCLUDING THE FOLLOWING:

READ AND FOLLOW ALL SAFETY INSTRUCTIONS

1. Mount only to an approved electrical enclosure.
2. Do not use near gas or electric heaters.
3. Equipment should be mounted in locations and at heights where it will not readily be subjected to tampering by unauthorized personnel.
4. Use of accessory equipment not recommended by the manufacturer may cause an unsafe condition.
5. Do not use this equipment for other than intended use.
6. Ambient temperature range is 32 - 122°F (0°- 50°C); Relative humidity range is 5 to 95%, noncondensing.
7. Maximum permitted load - Ballast : 20A @ 120/277 VAC, 50/60 Hz
LED Driver : 20A @ 120/277 VAC, 50/60 Hz
Incandescent: 10A @ 120 VAC, 50/60 Hz

SAVE THESE INSTRUCTIONS



WARNING: TURN POWER OFF AT CIRCUIT BREAKER BEFORE INSTALLING. ONLY QUALIFIED ELECTRICIANS SHOULD INSTALL THE BLCD-20B.

SERVICE BY QUALIFIED PERSONNEL ONLY

DESCRIPTION

The BLCD-20B works in conjunction with an auxiliary generator or central inverter system. The unit allows lighting control devices for normal lighting to also control emergency lighting installed within the area. The BLCD-20B is designed for lighting control in areas where emergency lighting fixtures are connected on dedicated emergency lighting circuits that are typically ON 24 hours per day. The BLCD-20B allows ON/OFF control of the emergency lighting along with the normal room lighting to save energy. The intended operation of the BLCD-20B is to guarantee that the emergency lighting is ON whenever normal power to the controlled circuit is interrupted. While normal power is present, the BLCD-20B allows control of the emergency lighting by a device such as an occupancy sensor, a relay, a dimmer, or a wall switch.

01/19/12

© Philips Emergency Lighting

A Division of Philips Electronics North America Corporation

236 Mt. Pleasant Rd. • Collierville, TN 38017-2752 • Tech Support 888-263-4638 • Fax 901-854-1630 • www.philips.com/bodine
70100045

INSTALLATION



WARNING: TURN POWER OFF AT CIRCUIT BREAKER BEFORE INSTALLING. ONLY QUALIFIED ELECTRICIANS SHOULD INSTALL THE BLCD-20B.

WIRING REFERENCE TABLE

	AWG/COLOR
Emergency Power In	12/Black
Emergency Neutral	18/Gray
Emergency Power Out	12/Red
Normal Power Sense	18/Black
Normal Neutral	18/White
Normal Switch Sense	18/Red

- BLCD-20B units shall be installed in accordance with state, local and national electrical codes and requirements.
- BLCD-20B units are designed to attach to a junction box or electrical enclosures that are fitted with a 7/8" diameter opening (standard 1/2" knockout).
- BLCD-20B units operate with power provided by two sources. Place a warning label on each enclosure that contains a BLCD-20B unit.

WIRING DIAGRAMS

LOAD CONTROL RELAY

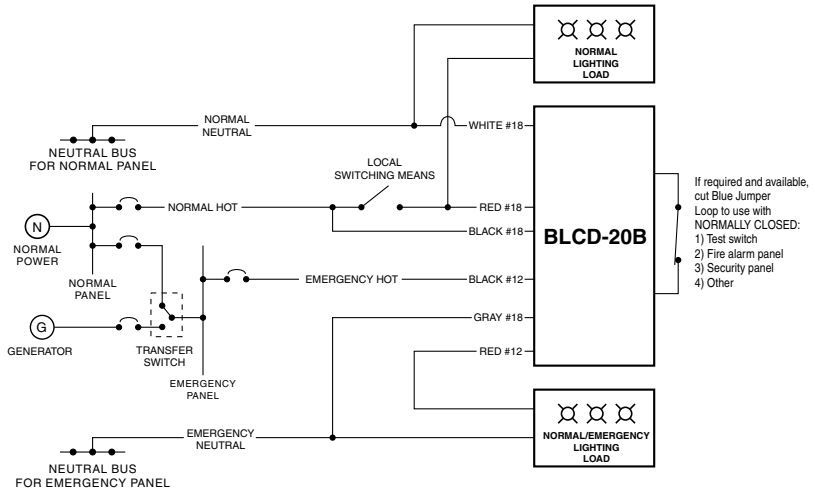

SWITCH BYPASS

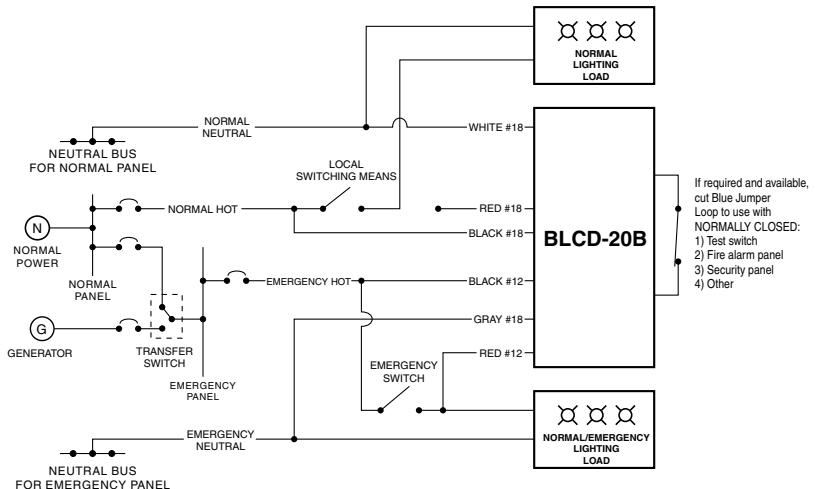

INSTALLATION

INSTALLATION PROCEDURE

- STEP #1** ► > Remove the locking nut from the BLCD-20B unit and insert the unit's threaded nipple through the appropriate knockout
- > Tighten the locking nut so that the unit is secured to the j-box or enclosure.
- STEP #2** ► > Connect the BLCD-20B to the emergency lighting for the area controlled.
- > Connect the Emergency wiring leads on the BLCD-20B in series with the emergency lighting load as shown in the wiring diagram.
- > Connect the neutral for the emergency circuit to the Emergency Neutral lead as shown in the wiring diagram.
- STEP #3** ► > Connect the BLCD-20B to the control device for the area controlled.
- > Connect the BLCD-20B's Normal wiring leads to the normal lighting circuit as shown in the wiring diagram.
- > Note that the Normal Power Sense connection should be made to the line side of the control device that serves the same area as the emergency lighting. This ensures that the emergency lighting in the controlled area turns ON during a localized power failure such as a tripped branch circuit breaker.

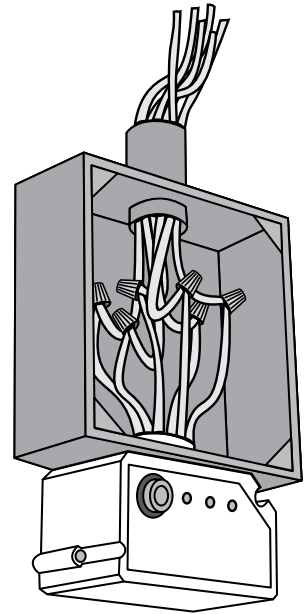

INSTALLING THE OPTIONAL REMOTE ACTIVATION DEVICE

The BLCD-20B provides leads for connection of a remote device that can force the unit into the emergency ON mode. The leads are in the form of a factory installed jumper loop (blue wire) on the BLCD-20B. When the loop is complete, it disables this function. Do not cut this jumper unless remote activation is desired. The device that provides remote activation of the emergency ON mode must provide a normally closed, maintained contact dry contact closure. The remote device opens the contacts to force the BLCD-20B into the emergency ON mode. The most common remote device is a test switch that is installed in an accessible location. Alternately, the blue wire leads can be used to allow another system such as a fire alarm or security system to force the BLCD-20B into the emergency ON mode.

- STEP #1** ► > Perform initial testing before cutting the blue wire jumper loop.
- STEP #2** ► > Cut the blue wire jumper loop.
- STEP #3** ► > Connect the two resulting leads on the BLCD-20B to the single pole contacts on the remote device or test switch.
- > The device must provide normally closed, maintained contact dry contact closure.
- > The remote device opens the circuit in order to force the BLCD-20B into the emergency ON mode.

TESTING



INITIAL TESTING SHOULD BE DONE WITH THE BLUE WIRE JUMPER LOOP INTACT TO LIMIT THE POSSIBILITY OF A REMOTE DEVICE AFFECTING THE TESTING.

- STEP #1** ► > Turn ON the circuit breaker in the emergency panel for the controlled circuit.
> The green LED on the BLCD-20B should glow.
> With only the emergency circuit ON (normal power OFF) the emergency lighting should be ON.
- STEP #2** ► > Temporarily disconnect and cap the wire connected to the Normal Switch Sense lead on the BLCD-20B.
> This disables the normal control function and allows definitive testing of the fail-to-ON functionality.
- STEP #3** ► > Turn ON the circuit breaker in the normal panel for the controlled circuit.
> The amber LED glows indicating that normal power is present and that emergency lighting is not required.
> The emergency lighting should turn OFF.
> Confirm the automatic emergency ON functionality by turning OFF the normal circuit breaker.
> The emergency lighting should immediately turn ON.
- STEP #4** ► > With the normal circuit breaker OFF, re-connect the wire to the Switch-In lead.
> Turn ON the normal circuit breaker.
> The control device now controls both the normal and emergency lighting together.

REMOTE ACTIVATION TEST

- STEP #1** ► > Remove the locking nut from the BLCD-20B unit and insert the unit's threaded nipple through the appropriate knockout
> Tighten the locking nut so that the unit is secured to the j-box or enclosure.
- STEP #2** ► > Connect the BLCD-20B to the emergency lighting for the area controlled. Connect the Emergency wiring leads on the BLCD-20B in series with the emergency lighting load as shown in the wiring diagram.
> Connect the neutral for the emergency circuit to the Emergency Neutral lead as shown in the wiring diagram.
- STEP #3** ► > Connect the BLCD-20B to the control device for the area controlled.
> Connect the BLCD-20B's Normal wiring leads to the normal lighting circuit as shown in the wiring diagram.
> Note that the Normal Power Sense connection should be made to the line side of the control device that serves the same area as the emergency lighting
> This ensures that the emergency lighting in the controlled area turns ON during a localized power failure such as a tripped branch circuit breaker.