

# B94CG

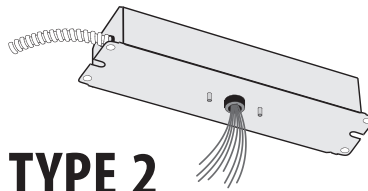

**PHILIPS**  
**bodine**

## Installation Instructions for TYPE 2

EMERGENCY LIGHTING EQUIPMENT



### **! IMPORTANT SAFEGUARDS !**

**WHEN USING ELECTRICAL EQUIPMENT, BASIC SAFETY PRECAUTIONS SHOULD ALWAYS BE FOLLOWED, INCLUDING THE FOLLOWING:**

## READ AND FOLLOW ALL SAFETY INSTRUCTIONS

1. To prevent high voltage from being present on red, yellow, and yellow/black output leads prior to installation, inverter connector must be open. Do not join inverter connector until installation is complete and AC power is supplied to the emergency ballast.
2. This product is for use with one 13 W through 42 W (4-pin) compact fluorescent lamp without integral starter.
3. Make sure all connections are in accordance with the National Electrical Code and any local regulations.
4. To reduce the risk of electric shock, disconnect both normal and emergency power supplies and inverter connector of the emergency ballast before servicing.
5. This emergency ballast is for factory or field installation.
6. This product is suitable for damp locations where the ambient ballast temperature is 0°C minimum, +50°C maximum. Product is not suitable for heated air outlets and wet or hazardous locations.
7. An unswitched AC power source is required (120 or 277 VAC, 60 Hz).
8. Do not install near gas or electric heaters.
9. Do not attempt to service the battery. A sealed, no-maintenance battery is used that is not field replaceable. Contact the manufacturer for information on service.
10. The use of accessory equipment not recommended by the manufacturer may cause an unsafe condition.
11. Do not use this product for other than intended use.
12. Servicing should be performed by qualified service personnel.

### SAVE THESE INSTRUCTIONS



Ni - Cd

**THIS PRODUCT CONTAINS A RECHARGEABLE NICKEL-CADMIUM BATTERY.  
THE BATTERY MUST BE RECYCLED OR DISPOSED OF PROPERLY.**

03/21/11

© Philips Emergency Lighting

A Division of Philips Electronics North America Corporation

# INSTALLATION



**WARNING: TO PREVENT HIGH VOLTAGE FROM BEING PRESENT ON RED, YELLOW, AND YELLOW/BLACK OUTPUT LEADS PRIOR TO INSTALLATION, INVERTER CONNECTOR MUST BE OPEN. DO NOT JOIN INVERTER CONNECTOR UNTIL INSTALLATION IS COMPLETE AND AC POWER IS SUPPLIED TO THE EMERGENCY BALLAST.**

**NOTE:** Make sure that the necessary branch circuit wiring is available. An unswitched source of power is required. The emergency ballast must be fed from the same branch circuit as the AC ballast.

## STEP #1 PRODUCT IDENTIFICATION AND INSTALLATION

- > Compare the emergency ballast to the illustrations below and determine the Option number necessary to identify the appropriate set of wiring diagrams.

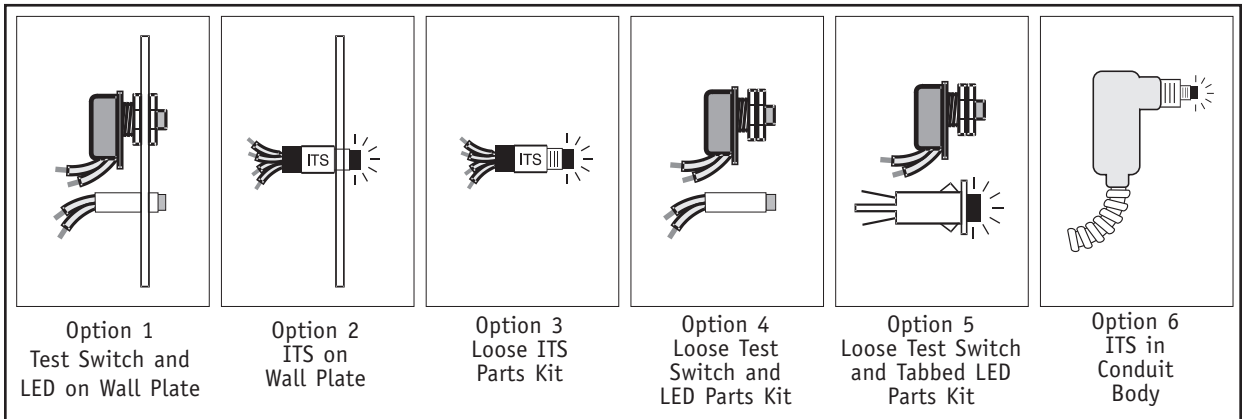

- > Disconnect AC power from the fixture.
- > Refer to the specific set of diagrams corresponding to the Option number determined above.
- > Make electrical connections in accordance with the National Electrical Code and any local regulations. If this product includes a test/monitor plate, it may be installed in the ceiling near the fixture or at a remote location (up to 50 feet). The emergency ballast may be remotely installed up to half the distance the AC ballast manufacturer recommends removing the AC ballast from the lamp, or up to 10 feet, whichever is less. If no AC ballast is used, the emergency ballast can be remotely mounted up to 10 feet away.
- > Note: A switch box is not supplied (for use with the test/monitor plate).
- > On switched fixtures, an additional unswitched hot wire (120 or 277 VAC) must be run and connected to the emergency ballast.

## STEP #2 WIRING THE EMERGENCY BALLAST

- > Cut the fixture wires between the lamp holder and AC ballasts and connect the blue and blue/white emergency ballast wires to the AC ballast and the yellow and yellow/black wires to the lamp holder.
- > Connect the LED by matching violet and brown leads. For optional tabbed LED, connect the violet lead to the positive (+) tab (marked). For the Illuminated Test Switch (ITS) connect as shown on the wiring diagrams by matching the violet and brown leads and connecting the black leads to the emergency ballast.
- > Follow the corresponding wiring diagram to connect the remaining leads.
- > After installation is complete, supply AC power to the emergency ballast and join the inverter connector.

## STEP #3 EMERGENCY BALLAST QUICK CHECK AND LABELING

- > For short-term testing of the emergency function, the battery must be charged for at least one hour. The emergency ballast must be charged for at least 24 hours before conducting a long-term test.
- > In a readily visible location, attach the label "CAUTION: This Unit Has More Than One Power Supply Connection Point. To Reduce The Risk Of Electrical Shock, Disconnect Both The Branch Circuit-Breakers Or Fuses And Emergency Power Supplies Before Servicing."

# OPERATION

When AC power is applied, the charging indicator light is illuminated, indicating that the battery is being charged. When power fails, the emergency ballast automatically switches to emergency power (internal battery), operating one lamp at reduced illumination. When AC power is restored, the emergency ballast returns to the charging mode and delays AC ballast operation for approximately three seconds to prevent false-tripping of AC ballast (end-of-lamp-life) shutdown circuits. This emergency ballast will operate one 13 W through 42 W lamp for a minimum of 90 minutes.

# MAINTENANCE

Although no routine maintenance is required to keep the emergency ballast functional, it should be checked periodically to ensure that it is working. The following schedule is recommended:

1. Visually inspect the charging indicator light monthly. It should be illuminated.
2. Test the emergency operation of the fixture at 30-day intervals for a minimum of 30 seconds. One lamp should operate at reduced illumination.
3. Conduct a 90-minute discharge test once a year. One lamp should operate at reduced illumination for at least 90 minutes.

**! REFER ANY SERVICING INDICATED BY THESE CHECKS TO QUALIFIED PERSONNEL !**

**EMERGENCY BALLAST AND AC BALLAST MUST BE FED FROM THE SAME BRANCH CIRCUIT**  
 TYPICAL SCHEMATICS ONLY. MAY BE USED WITH OTHER BALLASTS. CONSULT THE FACTORY FOR OTHER WIRING DIAGRAMS.

## WIRING DIAGRAMS for OPTIONS 1, 4 AND 5

ONE (1) 4-PIN COMPACT LAMP RAPID START BALLAST

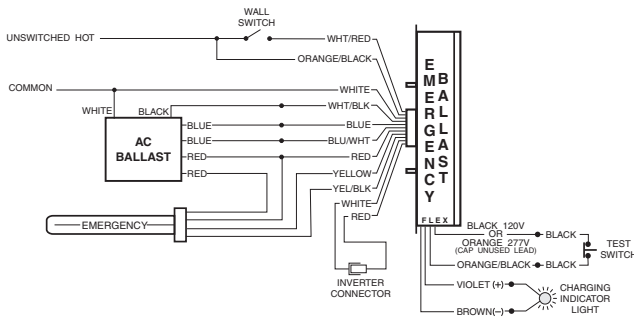

TWO (2) 4-PIN COMPACT LAMP RAPID START BALLAST

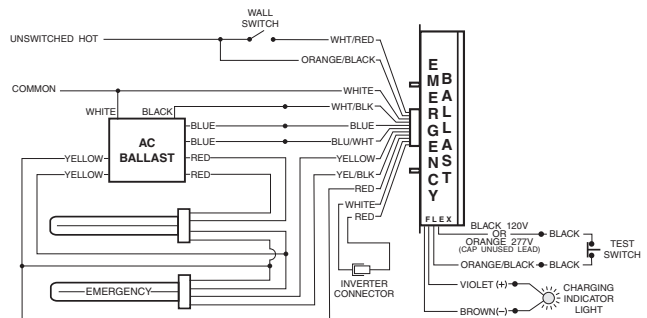

**EMERGENCY BALLAST AND AC BALLAST MUST BE FED FROM THE SAME BRANCH CIRCUIT**  
 TYPICAL SCHEMATICS ONLY. MAY BE USED WITH OTHER BALLASTS. CONSULT THE FACTORY FOR OTHER WIRING DIAGRAMS.

**WIRING DIAGRAMS for OPTIONS 2 AND 3**

ONE (1) 4-PIN COMPACT LAMP RAPID START BALLAST

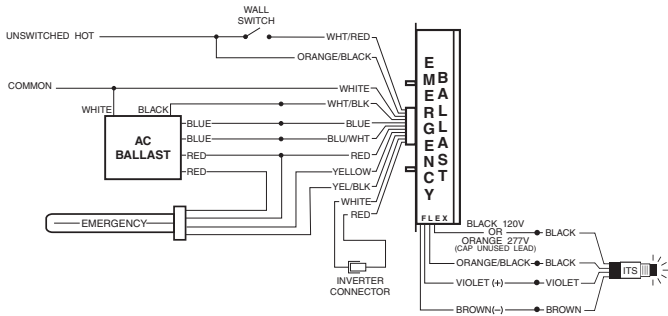

TWO (2) 4-PIN COMPACT LAMP RAPID START BALLAST

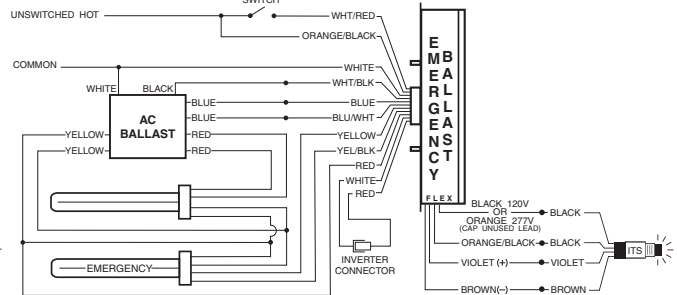

**WIRING DIAGRAMS for OPTION 6**

ONE (1) 4-PIN COMPACT LAMP RAPID START BALLAST

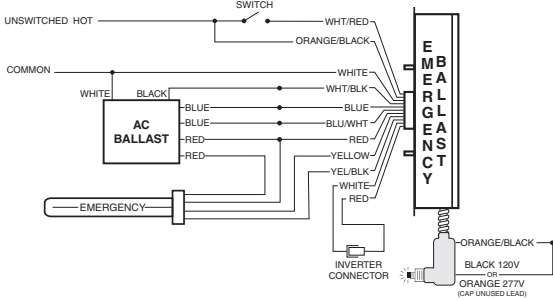

TWO (2) 4-PIN COMPACT LAMP RAPID START BALLAST

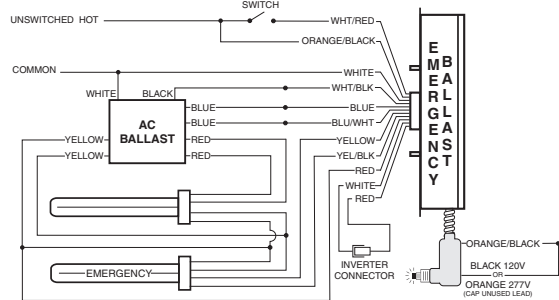

**NOTE: As with Option 2 wiring, one of the black ITS leads inside the conduit body must be connected to either the black (120 V) or orange (277 V) lead depending on system voltage. (UNUSED LEAD IS TO BE CAPPED)**

**WIRING DIAGRAM for OPTION 6 ( NO CONDUIT BODY)**

ONE (1) 4-PIN COMPACT LAMP RAPID START BALLAST

