

B33

Installation Instructions

FLUORESCENT EMERGENCY BALLAST

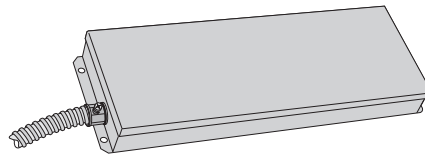

PHILIPS
bodine



! IMPORTANT SAFEGUARDS !

WHEN USING ELECTRICAL EQUIPMENT, BASIC SAFETY PRECAUTIONS SHOULD ALWAYS BE FOLLOWED, INCLUDING THE FOLLOWING:

READ AND FOLLOW ALL SAFETY INSTRUCTIONS

1. To prevent high voltage from being present on red, yellow, yellow/black, and yellow/red output leads prior to installation, inverter connector must be open. Do not join inverter connector until installation is complete and AC power is supplied to the emergency ballast.
2. This product is for use with two or three 32 W (4') T8 fluorescent lamps, two or three 36/39 W or two 40 W to 55 W (4-pin) long compact fluorescent lamps without integral starters. This product is for use with instant start parallel AC ballasts only.
3. Make sure all connections are in accordance with the National Electrical Code and any local regulations.
4. To reduce the risk of electric shock, disconnect both normal and emergency power supplies and inverter connector of the emergency ballast before servicing.
5. This emergency ballast is for factory or field installation.
6. This product is suitable for damp locations where the ambient temperature is +5°C minimum, +50°C maximum. Not suitable for heated air outlets and wet or hazardous locations.
7. An unswitched AC power source is required (120 or 277 VAC, 60 Hz).
8. Do not install near gas or electric heaters.
9. The battery is field replaceable. Contact manufacturer for information on replacement. Use caution when replacing battery. Dispose of battery properly. Do not incinerate.
10. The use of accessory equipment not recommended by the manufacturer may cause an unsafe condition.
11. Do not use this product for other than intended use.
12. Servicing should be performed by qualified service personnel.

SAVE THESE INSTRUCTIONS



Ni - Cd

**THIS PRODUCT CONTAINS A RECHARGEABLE NICKEL-CADMIUM BATTERY.
THE BATTERY MUST BE RECYCLED OR DISPOSED OF PROPERLY.**

12/21/10

© Philips Emergency Lighting

A Division of Philips Electronics North America Corporation

236 Mt. Pleasant Rd. • Collierville, TN USA 38017-2752 • Tech Support 888-263-4638 • Fax 901-854-1630 • www.philips.com/bodine
73000033

INSTALLATION



WARNING: TO PREVENT HIGH VOLTAGE FROM BEING PRESENT ON RED, YELLOW, YELLOW/BLACK, AND YELLOW/RED OUTPUT LEADS PRIOR TO INSTALLATION, INVERTER CONNECTOR MUST BE OPEN. DO NOT JOIN INVERTER CONNECTOR UNTIL INSTALLATION IS COMPLETE AND AC POWER IS SUPPLIED TO THE EMERGENCY BALLAST.

NOTE: Make sure that the necessary branch circuit wiring is available. An unswitched source of power is required. The emergency ballast must be fed from the same branch circuit as the AC ballast.

STEP #1 ▶ INSTALLING THE EMERGENCY BALLAST

- > Disconnect AC power from the fixture. Install the emergency ballast as shown. **Remote mounting distance must be less than half the maximum remote mounting distance for the AC ballast. Consult AC ballast manufacturer before remote installation.**

On Top of Fixture

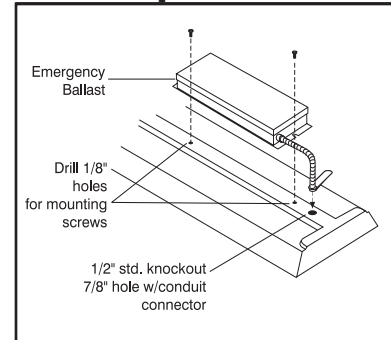

STEP #2 ▶ INSTALLING THE TEST SWITCH

- > Install the test switch through the ballast channel cover of a troffer or through the side of a strip fixture.
- > Drill a 1/2" hole and install the switch as shown.
- > Wire the test switch so that it removes AC power from both the emergency ballast and AC ballast at the same time (see wiring diagrams).

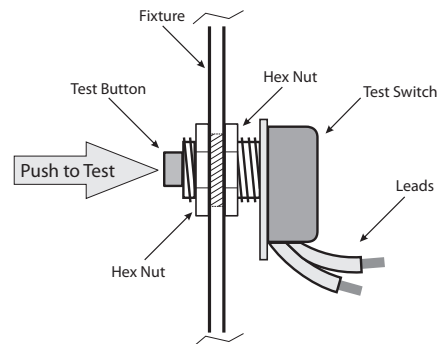

STEP #3 ▶ INSTALLING THE CHARGING INDICATOR LIGHT

- > Install the CHARGING INDICATOR LIGHT as shown so that it will be visible after the fixture is installed.

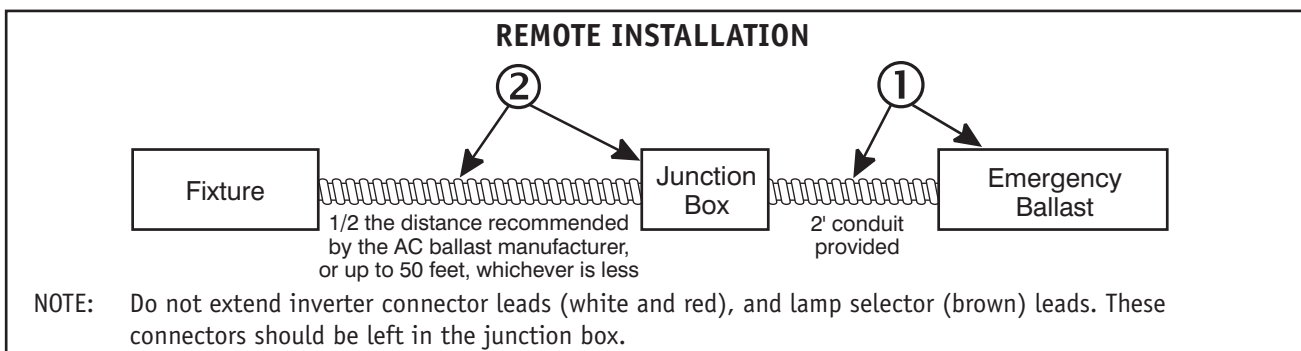

- 1 Emergency ballast with flexible conduit.
- 2 Conduit and junction box (not supplied), but necessary for remote installation.

STEP #4 ► WIRING THE EMERGENCY BALLAST

- > Determine the type of AC ballast installed in the fixture.
- > Select the appropriate wiring diagram on back to connect the emergency ballast to the AC ballast and lamps. Make electrical connections in accordance with the National Electrical Code and any local regulations.
- > After installation is complete, supply AC power to the emergency ballast and join the inverter connector.
- > At this point, power should be connected to both the AC ballast and the emergency ballast, and the Charging Indicator Light should illuminate indicating the battery is charging.
- > A short-term discharge test may be conducted after the emergency ballast has been charging for one hour. Charge for 24 hours before conducting a long-term discharge test. Refer to OPERATION.
- > In a readily visible location, attach the label "**CAUTION - This Unit Has More Than One Power Connection Point. To Reduce The Risk Of Electric Shock, Disconnect Both The Branch Circuit-Breakers Or Fuses And Emergency Power Supplies Before Servicing.**"

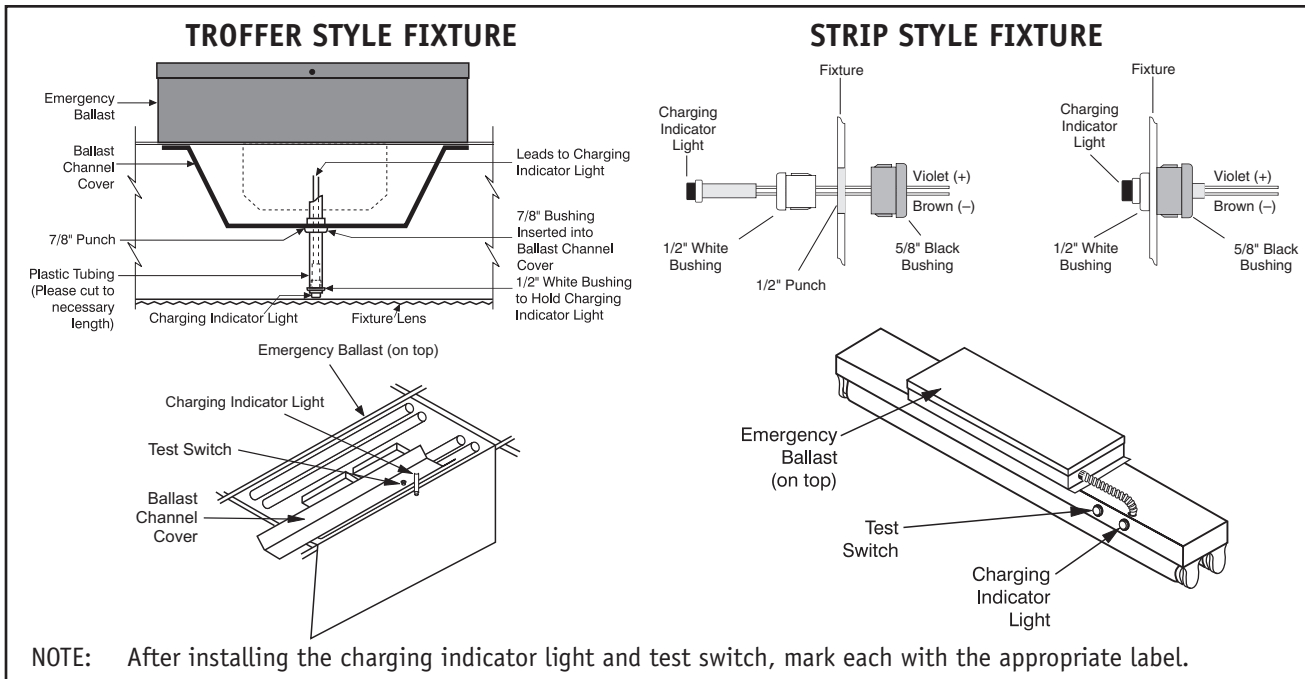

OPERATION

When AC power is applied, the charging indicator light is illuminated, indicating that the battery is being charged. When power fails, the emergency ballast automatically switches to emergency power (internal battery), operating either two or three lamps at reduced illumination for at least 90 minutes.

MAINTENANCE

Although no routine maintenance is required to keep the emergency ballast functional, it should be checked periodically to ensure that it is working. The following schedule is recommended:

1. Visually inspect the charging indicator light monthly. It should be illuminated.
2. Test the emergency operation of the fixture at 30-day intervals for a minimum of 30 seconds. Two or three lamps should operate at reduced illumination.
3. Conduct a 90-minute discharge test once a year. Two or three lamps should operate at reduced illumination for at least 90 minutes.
4. The life expectancy of the battery is 7 to 10 years. If the battery fails to provide 90 minutes of illumination, it should be replaced.

CAUTION: To replace battery, disconnect inverter connector and both switched and unswitched AC power from the fixture. Remove two screws (located on each end of lid), remove lid, and unplug and remove old battery. Plug in new battery, place inside ballast case, then replace lid and two screws. Supply AC power to fixture and reconnect inverter connector. Charging indicator light should be illuminated. Contact manufacturer for battery replacement.

! REFER ANY SERVICING INDICATED BY THESE CHECKS TO QUALIFIED PERSONNEL !



CAUTION: FOR USE WITH INSTANT START PARALLEL AC BALLASTS ONLY.

EMERGENCY BALLAST AND AC BALLAST MUST BE FED FROM THE SAME BRANCH CIRCUIT
TYPICAL SCHEMATICS ONLY. MAY BE USED WITH OTHER BALLASTS. CONSULT THE FACTORY FOR OTHER WIRING DIAGRAMS.

WIRING DIAGRAMS for 3-LAMP emergency operation

A. THREE (3) LAMP INSTANT START PARALLEL BALLAST

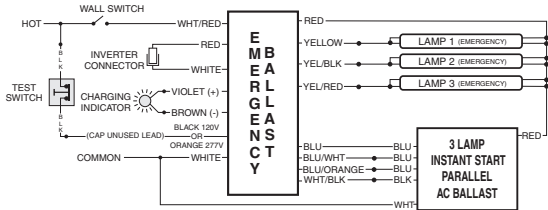

B. THREE (3) LONG COMPACT LAMP INSTANT START PARALLEL BALLAST

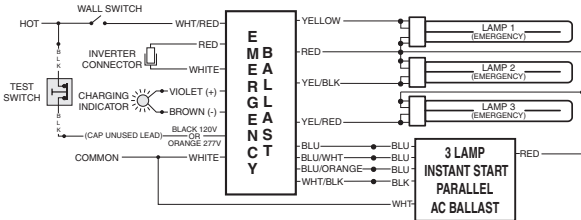

WIRING DIAGRAMS for 2-LAMP emergency operation

C. TWO (2) LAMP INSTANT START PARALLEL BALLAST

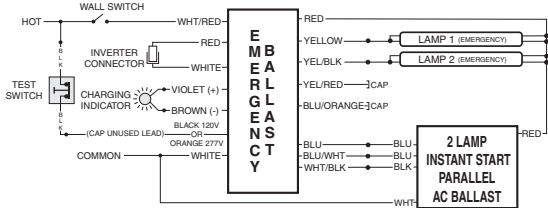

D. THREE (3) LAMP INSTANT START PARALLEL BALLAST

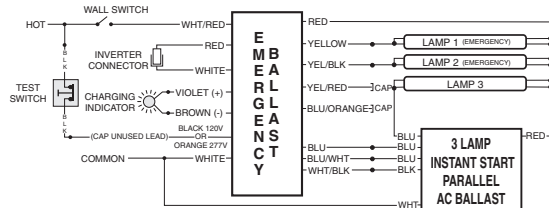

E. FOUR (4) LAMP INSTANT START PARALLEL BALLAST

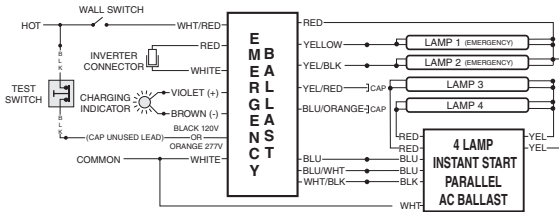

F. TWO (2) LONG COMPACT LAMP INSTANT START PARALLEL BALLAST

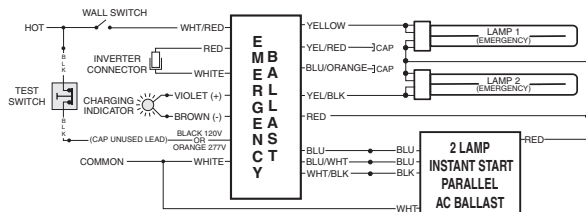

WIRING DIAGRAMS for Emergency-Only fixtures

G. TWO (2) LAMPS WITHOUT AC BALLAST

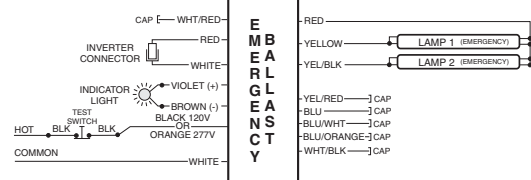

H. THREE (3) LAMPS WITHOUT AC BALLAST

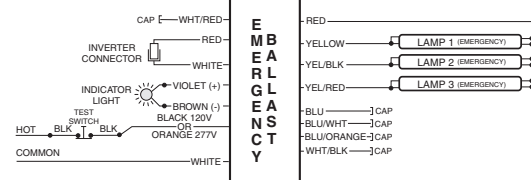

I. TWO (2) LONG COMPACT LAMPS WITHOUT AC BALLAST

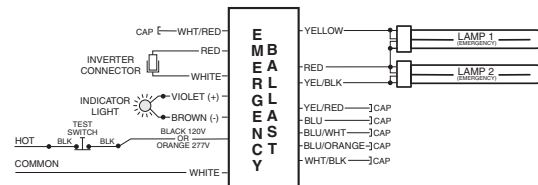

J. THREE (3) LONG COMPACT LAMPS WITHOUT AC BALLAST

