

# B30ST

## Installation Instructions

SELF-TESTING EMERGENCY LIGHTING EQUIPMENT

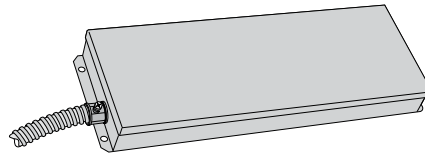

**PHILIPS**  
**bodine**



### **! IMPORTANT SAFEGUARDS !**

**WHEN USING ELECTRICAL EQUIPMENT, BASIC SAFETY PRECAUTIONS SHOULD ALWAYS BE FOLLOWED, INCLUDING THE FOLLOWING:**

## **READ AND FOLLOW ALL SAFETY INSTRUCTIONS**

1. To prevent high voltage from being present on red & yellow output leads prior to installation, inverter connector must be open. Do not join inverter connector until installation is complete and AC power is supplied to the emergency ballast.
2. This product is for use with most 17 W - 215 W T5, T8, T9, T10, or T12 single pin and bipin fluorescent lamps or 4-pin compact fluorescent lamps without integral starters.
3. Make sure all connections are in accordance with the National Electrical Code, Canadian Electrical Code and any local regulations.
4. To reduce the risk of electric shock, disconnect both normal and emergency power supplies and inverter connector of the emergency ballast before servicing.
5. This emergency ballast is for factory or field installation.
6. This product is suitable for damp locations where the ambient temperature is +5°C minimum, +50°C maximum. Not suitable for heated air outlets, wet or hazardous locations.
7. An unswitched AC power source is required (120 or 277 VAC, 60 Hz).
8. Do not install near gas or electric heaters.
9. The battery is field replaceable. Contact manufacturer for information on replacement. Use caution when replacing battery. Dispose of battery properly. Do not incinerate.
10. The use of accessory equipment not recommended by the manufacturer may cause an unsafe condition.
11. Do not use this product for other than intended use.
12. Servicing should be performed by qualified service personnel.

## **SAVE THESE INSTRUCTIONS**

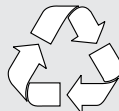

Ni - Cd

**THIS PRODUCT CONTAINS A RECHARGEABLE NICKEL-CADMIUM BATTERY.  
THE BATTERY MUST BE RECYCLED OR DISPOSED OF PROPERLY.**

06/16/11

© Philips Emergency Lighting

A Division of Philips Electronics North America Corporation

236 Mt. Pleasant Rd. • Collierville, TN USA 38017-2752 • Tech Support 888-263-4638 • Fax 901-854-1630 • [www.philips.com/bodine](http://www.philips.com/bodine)  
73000026

# INSTALLATION



**WARNING: TO PREVENT HIGH VOLTAGE FROM BEING PRESENT ON RED & YELLOW OUTPUT LEADS PRIOR TO INSTALLATION, INVERTER CONNECTOR MUST BE OPEN. DO NOT JOIN INVERTER CONNECTOR UNTIL INSTALLATION IS COMPLETE AND AC POWER IS SUPPLIED TO THE EMERGENCY BALLAST.**

**NOTE:** Make sure that the necessary branch circuit wiring is available. An unswitched source of power is required. The emergency ballast must be fed from the same branch circuit as the AC ballast.

## STEP #1 ▶ INSTALLING THE EMERGENCY BALLAST

- > Disconnect AC power from the fixture.
- > Depending on the type of fixture in use install emergency ballast using one of the methods illustrated below. Mount the emergency ballast on top of the fixture. The emergency ballast may be remotely installed up to 1/2 the distance the AC ballast manufacturer recommends removing the AC ballast from the lamp, or up to 50 feet, whichever is less.

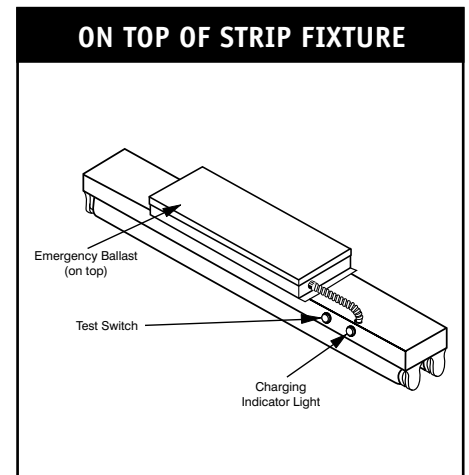
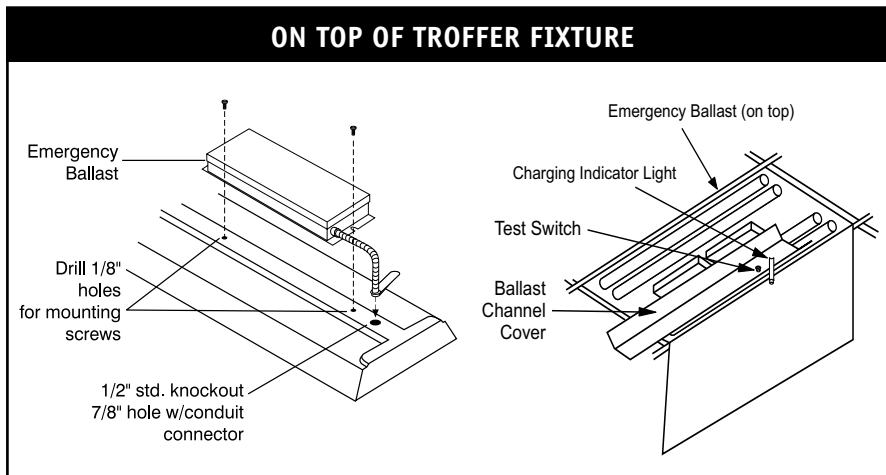

## STEP #2 ▶ INSTALLING THE ILLUMINATED TEST SWITCH (ITS) (PROVIDED UPON REQUEST ONLY) (OPTIONAL)

- > Please refer to the Illuminated Test Switch (ITS) installation instructions (provided with ITS) and skip steps #3 and #4.

## STEP #3 ▶ INSTALLING THE TEST SWITCH

- > Refer to the illustrations above and install the test switch through the ballast channel cover of a troffer or through the side of a strip fixture.
- > Drill a 1/2" hole and install the switch as shown.
- > Refer to the wiring diagrams and wire the test switch so that it removes AC power from both the emergency ballast and the AC ballast at the same time.

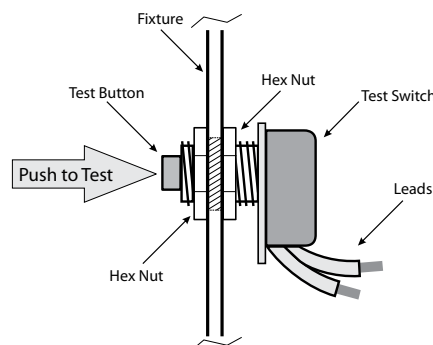

## STEP #4 ► INSTALLING THE CHARGING INDICATOR LIGHT

- > Install the CHARGING INDICATOR LIGHT as shown in the illustration below so that it will be visible after the fixture is installed.

### TROFFER STYLE FIXTURE

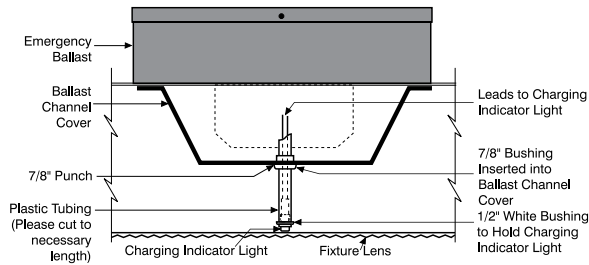

### STRIP STYLE FIXTURE

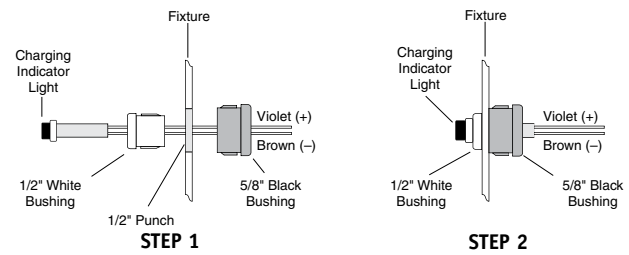

NOTE: After installing the charging indicator light and test switch, mark each with the appropriate label.

## STEP #5 ► WIRING THE EMERGENCY BALLAST

- > Determine the type of AC ballast installed in the fixture.
- > Select the appropriate wiring diagram to connect the emergency ballast to the AC ballast and lamp(s). Make electrical connections in accordance with the National Electrical Code, Canadian Electrical Code and any local regulations.
- > After installation is complete, supply AC power to the emergency ballast and join the inverter connector.
- > At this point, power should be connected to both the AC ballast and the emergency ballast, and the Charging Indicator Light should illuminate indicating the battery is charging.
- > A short-term discharge test may be conducted after the emergency ballast has been charging for one hour. Charge for 24 hours before conducting a long-term discharge test. **Refer to OPERATION.**
- > In a readily visible location, attach the label **"CAUTION - This Unit Has More Than One Power Connection Point. To Reduce The Risk Of Electric Shock, Disconnect Both The Branch Circuit-Breakers Or Fuses And Emergency Power Supplies Before Servicing."**
- > To disarm audible alarm, cut red/white wire loop (CAP ENDS).

## OPERATION

During normal operation, AC power is applied and the self-testing emergency ballast charges the battery. Connecting the (red and white) inverter connector wires enables the emergency circuit, and supplies power to the control/monitor circuit and charging indicator light. The self-testing emergency ballast continually monitors the charging current and battery voltage, comparing them to preset limits. Should the unit detect an unusual current or voltage condition, the indicator light will flash and the internal audible alarm will sound.

When AC power fails, the self-testing emergency ballast automatically switches to emergency mode, keeping either one or two lamps illuminated at a reduced lumen output for a minimum of 90 minutes. When AC power is restored, the self-testing emergency ballast returns to charging mode and delays AC ballast operation for approximately three seconds to prevent false tripping of AC ballast (end-of-lamp life) shutdown circuits.

## SELF-TESTING OPERATION

This unit contains a control/monitor circuit that automatically performs a 30-second discharge test every 30 days, and a full 90-minute discharge test once a year. During routine testing, the self-testing emergency ballast simulates an AC power failure causing the unit to automatically switch to emergency mode. The unit will monitor the operation of the lamps, battery voltage, discharge current, and emergency duration. If the emergency system functions properly, then the unit will return to normal mode. Should the unit detect any problems, the indicator light will flash continually and the audible alarm will sound 4 times every 30 seconds until the condition has been corrected or the unit passes the next test.

To reset a failure indication, push and hold the test switch for a minimum of 15 seconds. If the condition has not been corrected by the next scheduled test, the unit will once again detect the failure and signal the failure indicator.

**To cancel a test, turn the wall switch ON (or OFF if switch is already on), wait 5 seconds, then turn it OFF (ON).**

# MAINTENANCE

This self-testing emergency ballast automatically performs required routine testing. Results are reported to maintenance personnel via the indicator light and audible alarm.

**Note:** If optional audible alarm is disabled, maintenance personnel should periodically check the indicator light. If the indicator light is flashing, go through all steps of *Troubleshooting Guide*.

## TROUBLESHOOTING GUIDE

STATUS INDICATORS		PROBLEM	CONNECTOR
INDICATOR LIGHT	AUDIBLE ALARM		
Light on steady, not flashing	No beeping	None	Unit is Operating Correctly.
Flashing 1/2 Second Intervals	Beeping 1/2 Second Intervals	Line voltage; incorrect installation	Check line voltage. For 120 VAC use black as hot; for 277 VAC use orange as hot wire lead.
Flashing 1/2 Second Intervals	Beeping 4 times every 30 seconds	Battery voltage is outside limits.	Let battery charge. If after an hour failure is still indicated, see action below.
		Failed scheduled self-test	<ol style="list-style-type: none"> <li>1. Check to make sure lamps are good (operational and specified for self-testing emergency ballast) and in place.</li> <li>2. Check to see if brown connector is properly used. (See Table 1.)</li> <li>3. Check that fixture wiring is in accordance with proper wiring diagram.</li> <li>4. Allow unit to charge for 24 hours. Perform manual test. If flashing/beeping continue, emergency ballast should be replaced.</li> </ol>
Any other erroneous status indications		Corrupted chip memory	Open inverter connector (red and white wires) and push manual test switch for 15 seconds minimum, then reconnect battery connector.

### Failure Status will be reset when the unit passes:

- The next automatic test, or
- A manual test exceeding 15 seconds, or
- An actual power failure exceeding 15 seconds.

**NOTE:** It is normal for the indicator light to remain off for a few minutes on initial start-up or after a very long power outage (discharge), as the battery voltage rises to normal range. Refer to the Troubleshooting Guide if this condition persists.

# B30ST WIRING DIAGRAMS

The following diagrams are typical schematics only. May be used with other ballasts.  
Consult the factory for other wiring diagrams.  
**EMERGENCY BALLAST AND AC BALLAST MUST BE FED FROM THE SAME BRANCH CIRCUIT.**

Table 1 - Lamp Compatibility

LAMP DIAMETER (T8, T9, T10, T12)	BASE	WATTAGE (Length)	NO. of LAMPS (EMERGENCY)	BROWN CONNECTOR
1", 1¼", 1½"	Single or Bipin	17 - 40 W (2' - 4')	1	CLOSED
		40 - 215 W (5' - 8')	2	OPEN
Long Compact	4-PIN (2G11)	18 - 39 W	1	CLOSED
		40 - 55 W	2	OPEN
Twin/Quad Twin-Tube Compact	4-PIN (G24q, GX24q)	18 - 42 W	1	CLOSED
			2	OPEN
2D	4-PIN (GR10q)	16 - 38 W	1	CLOSED
		55 W	2	OPEN
T5 (5/8")	Bipin	14 - 54 W (2' - 4')	1	CLOSED

**Important: Refer to Table 1 before connecting the brown connector.**

## WIRING DIAGRAMS for 1-LAMP emergency operation

### RAPID START AC BALLASTS

FIG A ONE (1) LAMP RAPID START BALLAST

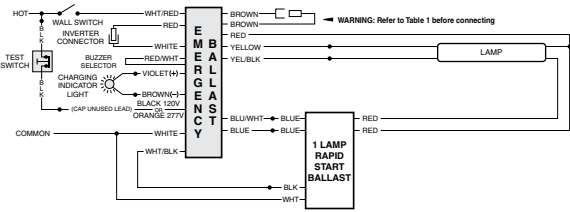

### INSTANT START AC BALLASTS

FIG B ONE (1) LAMP INSTANT START BALLAST

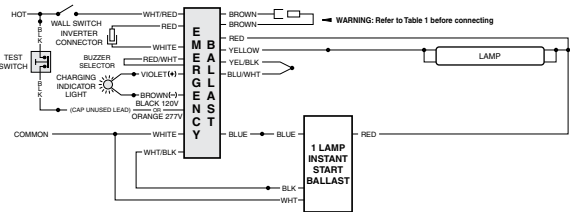

FIG C TWO (2) LAMP RAPID START BALLAST

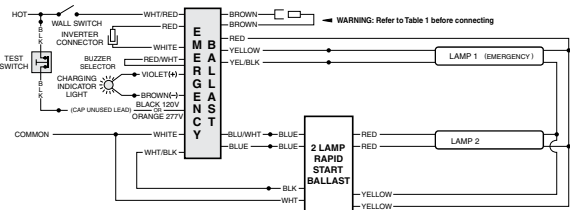

FIG D TWO (2) LAMP INSTANT START BALLAST

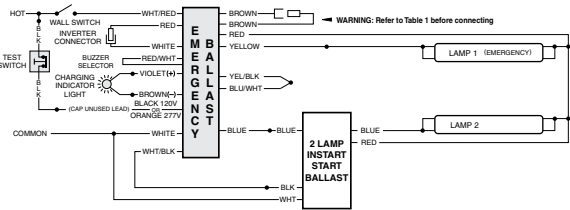

FIG E THREE (3) LAMP RAPID START BALLAST

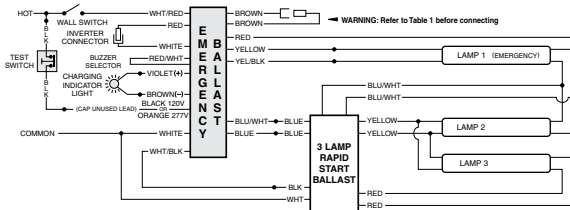

FIG F THREE (3) LAMP INSTANT START BALLAST

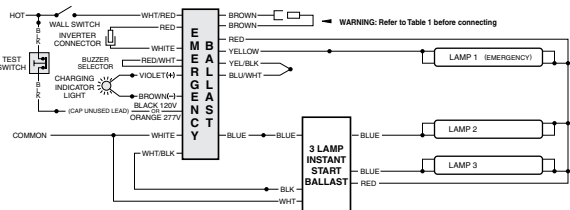

FIG G FOUR (4) LAMP RAPID START BALLAST

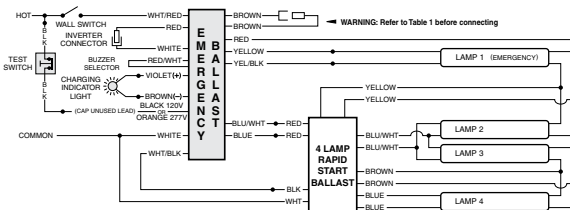
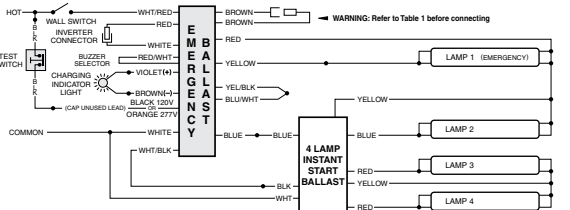

FIG H FOUR (4) LAMP INSTANT START BALLAST



**EMERGENCY BALLAST AND AC BALLAST MUST BE FED FROM THE SAME BRANCH CIRCUIT**  
 TYPICAL SCHEMATICS ONLY. MAY BE USED WITH OTHER BALLASTS. CONSULT THE FACTORY FOR OTHER WIRING DIAGRAMS.

## WIRING DIAGRAM for 1-LAMP emergency operation

FIG I ONE (1) LAMP COMPACT RAPID START BALLAST

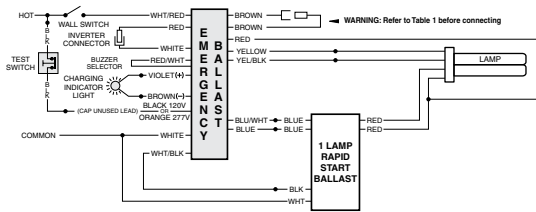

FIG J TWO (2) LAMP COMPACT RAPID START BALLAST

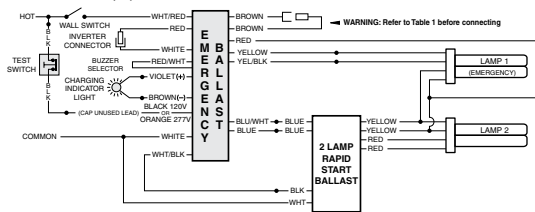
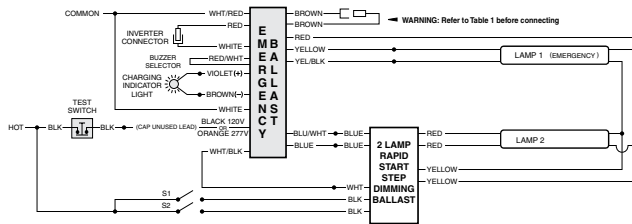

FIG K TWO (2) LAMP RAPID START STEP DIMMING BALLAST



THE WHITE/BLACK LEAD MUST CONNECT TO THE WHITE LEAD OF THE STEP-DIMMING BALLAST ASSOCIATED WITH THE EMERGENCY BALLAST ONLY. CONNECTIONS TO OTHER BALLASTS OR FIXTURES COULD RESULT IN ABNORMAL OPERATION AND CAUSE PRODUCT DAMAGE.

## WIRING DIAGRAMS for 2-LAMP emergency operation (2' - 4', 17- 40 W lamps only)

Two-lamp emergency operation is not possible with all ballasts.  
 Consult the factory for any ballast other than those shown.

FIG L TWO (2) LAMP RAPID START BALLAST

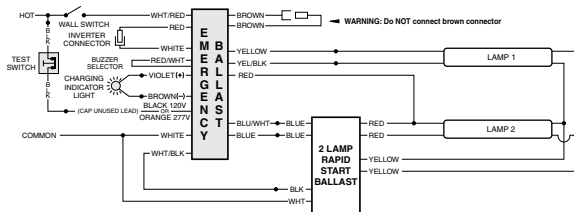

FIG M TWO (2) LAMP INSTANT START BALLAST

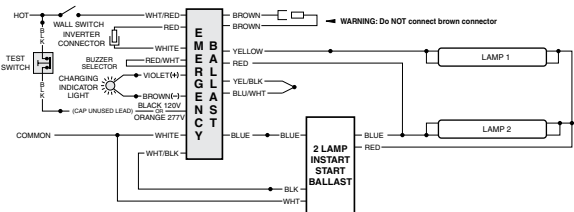

FIG N THREE (3) LAMP RAPID START BALLAST

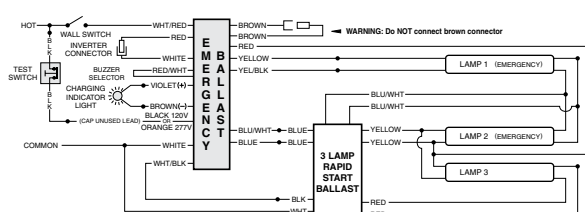

FIG O THREE (3) LAMP INSTANT START BALLAST

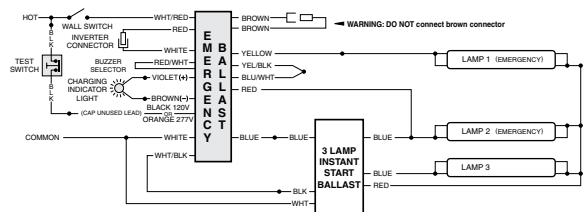

FIG P FOUR (4) LAMP RAPID START BALLAST

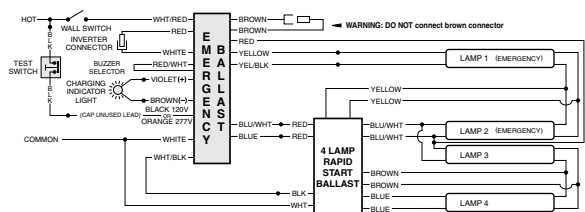

FIG Q FOUR (4) LAMP INSTANT START BALLAST

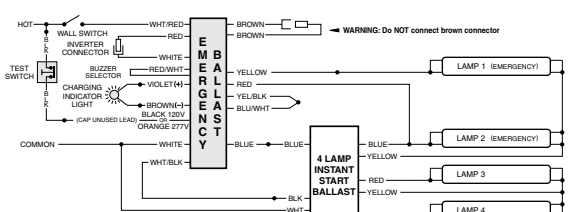
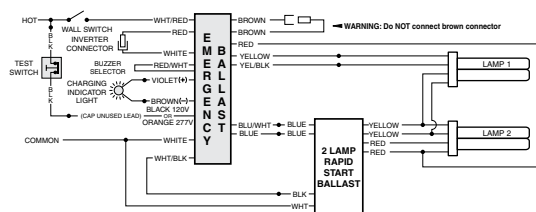

FIG R TWO (2) COMPACT LAMP RAPID START BALLAST



# B30ST WIRING DIAGRAMS

## WIRING DIAGRAM for EMERGENCY-ONLY fixtures

FIG S TWO (2) LAMPS WITHOUT AC BALLAST (17-40W)

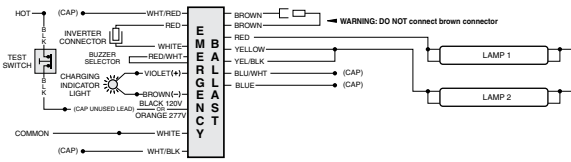

FIG T ONE (1) LAMP WITHOUT AC BALLAST (16-42W)

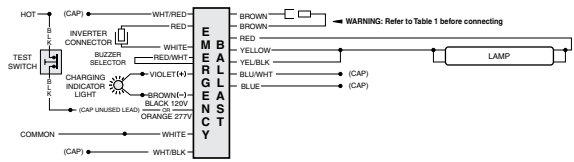

FIG U ONE (1) 4-PIN COMPACT LAMP WITHOUT AC BALLAST (16-55W)

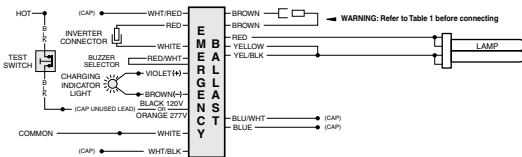
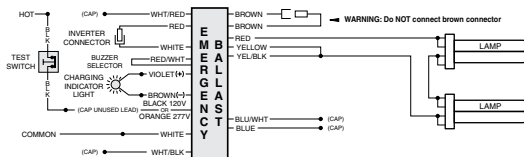

FIG V TWO (2) 4-PIN COMPACT LAMPS WITHOUT AC BALLAST (16-42W)



**NOTE: Installation of this self-testing fluorescent emergency ballast is different from standard models. The emergency ballast must interrupt the switched or unswitched hot lead feeding the AC ballast. Before beginning installation, consult these wiring diagrams.**