

B30RCT

Installation Instructions

REMOTE CONTROL TESTING EMERGENCY BALLAST

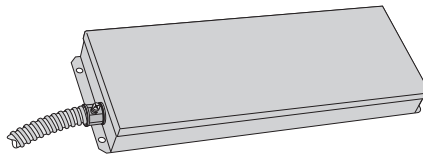

PHILIPS
bodine



! IMPORTANT SAFEGUARDS !

WHEN USING ELECTRICAL EQUIPMENT, BASIC SAFETY PRECAUTIONS SHOULD ALWAYS BE FOLLOWED, INCLUDING THE FOLLOWING:

READ AND FOLLOW ALL SAFETY INSTRUCTIONS

1. To prevent high voltage from being present on red & yellow output leads prior to installation, inverter connector must be open. Do not join inverter connector until installation is complete and AC power is supplied to the emergency ballast.
2. This product is for use with most 17 W - 215 W T5, T8, T9, T10, or T12 single pin and bipin fluorescent lamps or 4-pin compact fluorescent lamps without integral starters.
3. Make sure all connections are in accordance with the National Electrical Code or Canadian Electrical Code and any local regulations.
4. To reduce the risk of electric shock, disconnect both normal and emergency power supplies and inverter connector of the emergency ballast before servicing.
5. This emergency ballast is for factory or field installation.
6. This product is suitable for damp locations where the ambient temperature is +5°C minimum, +50°C maximum. Product is not suitable for heated air outlets and wet or hazardous locations.
7. An unswitched AC power source is required (120 or 277 VAC, 60 Hz).
8. Do not install near gas or electric heaters.
9. The battery is field replaceable. Contact manufacturer for information on replacement. Use caution when replacing battery. Dispose of battery properly. Do not incinerate.
10. The use of accessory equipment not recommended by the manufacturer may cause an unsafe condition.
11. Do not use this product for other than intended use.
12. Servicing should be performed by qualified service personnel.

SAVE THESE INSTRUCTIONS



Ni - Cd

**THIS PRODUCT CONTAINS A RECHARGEABLE NICKEL-CADMIUM BATTERY.
THE BATTERY MUST BE RECYCLED OR DISPOSED OF PROPERLY.**

12/21/10

© Philips Emergency Lighting

A Division of Philips Electronics North America Corporation

236 Mt. Pleasant Rd. • Collierville, TN USA 38017-2752 • Tech Support 888-263-4638 • Fax 901-854-1630 • www.philips.com/bodine
73000041

INSTALLATION



WARNING: TO PREVENT HIGH VOLTAGE FROM BEING PRESENT ON RED & YELLOW OUTPUT LEADS PRIOR TO INSTALLATION, INVERTER CONNECTOR MUST BE OPEN. DO NOT JOIN INVERTER CONNECTOR UNTIL INSTALLATION IS COMPLETE AND AC POWER IS SUPPLIED TO THE EMERGENCY BALLAST.

NOTE: Make sure that the necessary branch circuit wiring is available. An unswitched source of power is required. The emergency ballast must be fed from the same branch circuit as the AC ballast.

STEP #1 ▶ INSTALLING THE EMERGENCY BALLAST

- > Disconnect AC power from the fixture. Install the emergency ballast as shown. **Remote mounting distance must be less than half the maximum remote mounting distance for the AC ballast. Consult AC ballast manufacturer before remote installation.**

On Top of Fixture

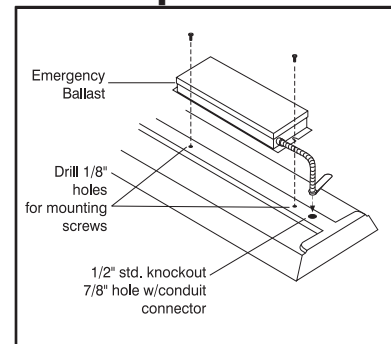

STEP #2 ▶ INSTALLING THE TEST SWITCH

- > Install the test switch through the ballast channel cover of a troffer or through the side of a strip fixture.
- > Drill a 1/2" hole and install the switch as shown.
- > Wire the test switch so that it removes AC power from both the emergency ballast and AC ballast at the same time (see wiring diagrams).

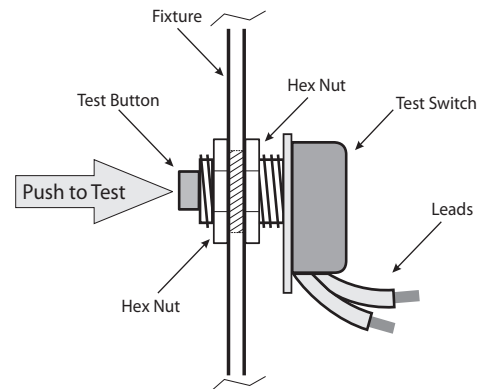

STEP #3 ▶ INSTALLING THE CHARGING INDICATOR LIGHT

- > Install the CHARGING INDICATOR LIGHT as shown in Illustration 1 so that it will be visible after the fixture is installed.

STEP #4 ▶ INSTALLING THE INFRARED RECEIVER

- > Refer to the Illustration 2 and install the infrared receiver and cable assembly as shown. The infrared receivers should be installed flush against the fixture lens and allows line of sight assess with hand held remote control transmitter (Bodine Model WHRCT sold separately).

STEP #5 ► WIRING THE EMERGENCY BALLAST

- > Determine the type of AC ballast installed in the fixture.
- > Select the appropriate wiring diagram on back to connect the emergency ballast to the AC ballast and lamp(s). Make electrical connections in accordance with the National Electrical Code, Canadian Electrical Code and any local regulations.
- > After installation is complete, supply AC power to the emergency ballast and join the inverter connector.
- > At this point, power should be connected to both the AC ballast and the emergency ballast, and the Charging Indicator Light should illuminate indicating the battery is charging.
- > A short-term discharge test may be conducted after the emergency ballast has been charging for one hour. Charge for 24 hours before conducting a long-term discharge test. Refer to OPERATION.
- > In a readily visible location, attach the label "**CAUTION - This Unit Has More Than One Power Connection Point. To Reduce The Risk Of Electric Shock, Disconnect Both The Branch Circuit-Breakers Or Fuses And Emergency Power Supplies Before Servicing.**"

ILLUSTRATION 1 INSTALLING THE CHARGING INDICATOR LIGHT

TROFFER STYLE FIXTURE

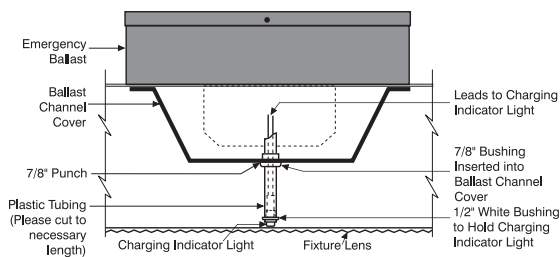

STRIP STYLE FIXTURE

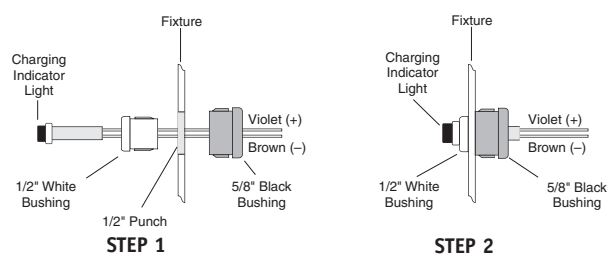
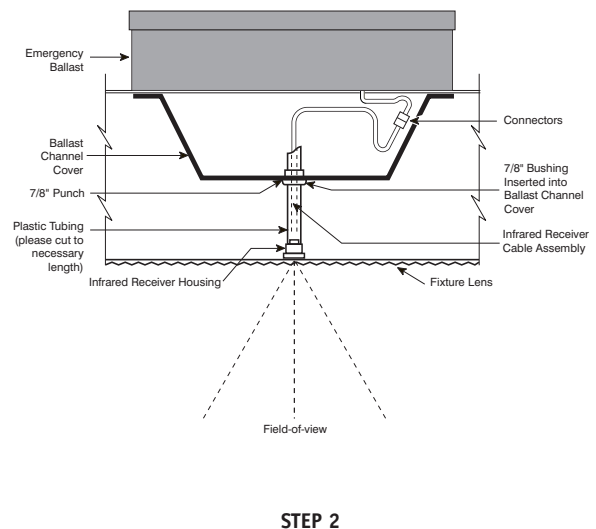
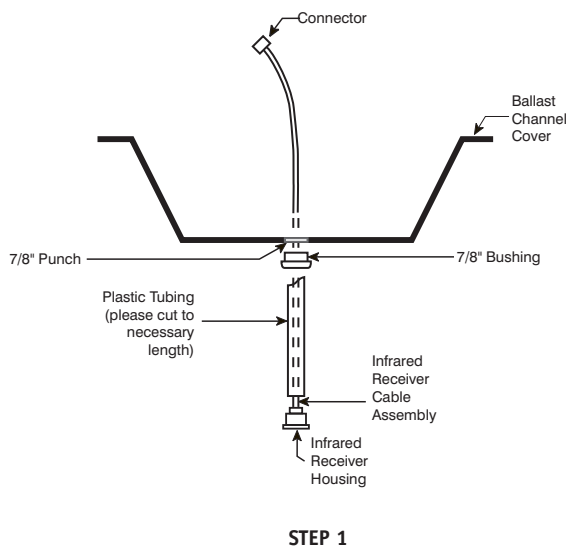

ILLUSTRATION 2 INSTALLING THE INFRARED DETECTOR



Feed infrared receiver cable assembly connector through plastic tubing, 7/8" bushing, and ballast channel cover. Insert infrared receiver housing into plastic tubing.

Slide plastic tubing through 7/8" bushing. Connect infrared receiver cable assembly to emergency ballast.

OPERATION

When AC power is applied, the charging indicator light is illuminated, indicating that the battery is being charged. When power fails, the emergency ballast automatically switches to emergency power (internal battery), operating either one or two lamps at reduced illumination for at least 90 minutes. When AC power is restored, the emergency ballast returns to charging mode and delays AC ballast operation for approximately three seconds to prevent false tripping of AC ballast (end-of-lamp life) shutdown circuits.

MAINTENANCE

Although no routine maintenance is required to keep the emergency ballast functional, it should be checked periodically to ensure that it is working. The following schedule is recommended:

1. Visually inspect the charging indicator light monthly. It should be illuminated.
2. Test the emergency operation of the fixture at 30-day intervals for a minimum of 30 seconds. One or two lamps should operate at reduced illumination.
3. Conduct a 90-minute discharge test once a year. One or two lamps should operate at reduced illumination for at least 90 minutes.
4. The life expectancy of the battery is 7 to 10 years. If the battery fails to provide 90 minutes of illumination, it should be replaced.

CAUTION: To replace battery, disconnect inverter connector and both switched and unswitched AC power from the fixture. Remove two screws (located on each end of lid), remove lid, and unplug and remove old battery. Plug in new battery, place inside ballast case, then replace lid and two screws. Supply AC power to fixture and reconnect inverter connector. Charging indicator light should be illuminated. Contact manufacturer for battery replacement.

! REFER ANY SERVICING INDICATED BY THESE CHECKS TO QUALIFIED PERSONNEL !

REMOTE CONTROL TESTING

The B30RCT offers the unique option of testing the emergency ballast from a remote location. A handheld remote control transmitter (Bodine Model WHRCT, sold separately) is required to use this feature. Testing of emergency ballast operation can still be accomplished by turning AC power off at the circuit breaker or by depressing the test switch.

Remote Control Transmitter Operation: The handheld remote control transmitter has three (3) push-buttons: one for executing a **30-second test**, one for executing a **90-minute test**, and one to abort either test and **reset** the emergency ballast to the "normal" charging mode. The push-buttons are momentary action; hence, they do not need to be held down. The remote control simply initiates the action; however, the function and timing are controlled by the electronics within the emergency ballast.

After fixture installation is complete and AC power is supplied to the fixture, stand beneath the fixture to be tested and point the remote control transmitter at the infrared receiver. Press the **30-second** or **90-minute test** button on the remote control transmitter. The emergency ballast automatically simulates a power outage and runs the lamp(s) from its internal battery for 30 seconds or 90 minutes (depending on the test button selected). (Note: the emergency ballast must charge for at least 24 hours before performing a 90-minute test).

To abort a test at any time, point the remote control transmitter at the infrared receiver and press the **reset** button. The emergency ballast automatically restores the fixture to its operational state before the test.

Note: Use the handheld remote control transmitter near the fixture and within the receiver field-of-view (see Illustration 2).

B30RCT WIRING DIAGRAMS

The following diagrams are typical schematics only. May be used with other ballasts.
 Consult the factory for other wiring diagrams.
EMERGENCY BALLAST AND AC BALLAST MUST BE FED FROM THE SAME BRANCH CIRCUIT.

Table 1 - Lamp Compatibility

LAMP DIAMETER (T8, T9, T10, T12)	BASE	WATTAGE (Length)	NO. of LAMPS (EMERGENCY)	BROWN CONNECTOR
1", 1 1/4", 1 1/2"	Single or Bipin	17 - 40 W (2' - 4')	1	CLOSED
		32 - 215 W (5' - 8')	2	OPEN
Long Compact	4-PIN (2G11)	18 - 39 W	1	CLOSED
		40 - 55 W	2	OPEN
Twin/Quad Twin-Tube Compact	4-PIN (G24q, GX24q)	18 - 42 W	1	CLOSED
			2	OPEN
2D	4-PIN (GR10q)	16 - 38 W	1	CLOSED
			2	OPEN
		55 W	1	OPEN
T5 (5/8")	Bipin	14 - 54 W (2' - 4')	1	CLOSED

WIRING DIAGRAMS for 1-LAMP emergency operation

RAPID START AC BALLASTS

FIG A ONE (1) LAMP RAPID START BALLAST

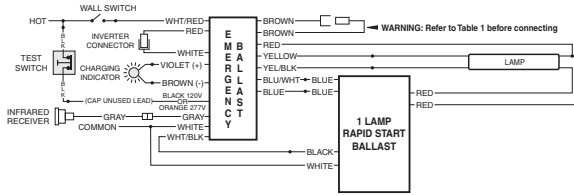

INSTANT START AC BALLASTS

FIG B ONE (1) LAMP INSTANT START BALLAST

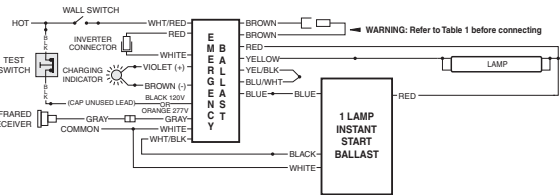

FIG C TWO (2) LAMP RAPID START BALLAST

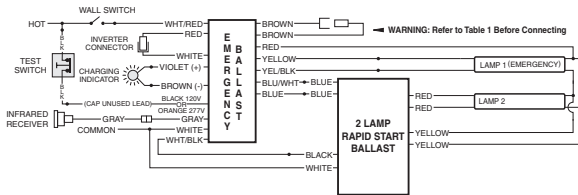

FIG D TWO (2) LAMP INSTANT START BALLAST

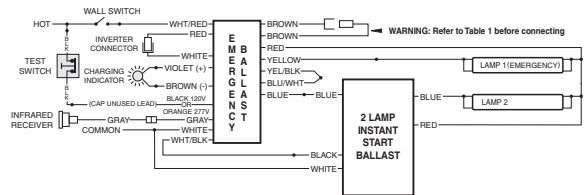

FIG E THREE (3) LAMP RAPID START BALLAST

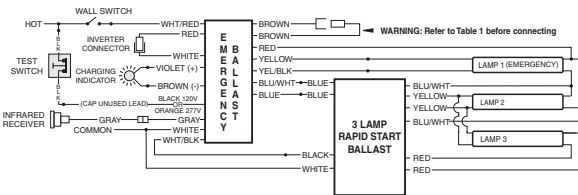

FIG F THREE (3) LAMP INSTANT START BALLAST

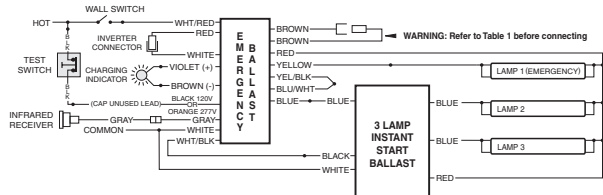

FIG G FOUR (4) LAMP RAPID START BALLAST

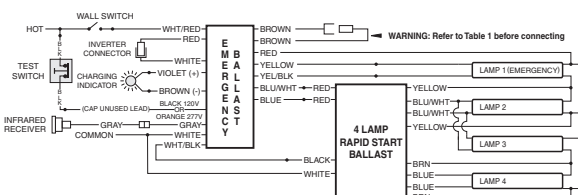
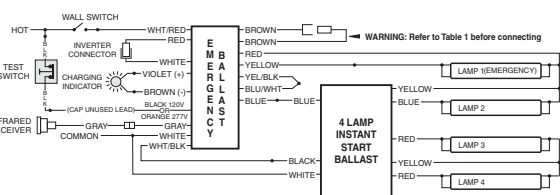

FIG H FOUR (4) LAMP INSTANT START BALLAST



B30RCT WIRING DIAGRAMS

WIRING DIAGRAMS for 2-LAMP emergency operation (2' - 4', 17- 40 W lamps only)

RAPID START AC BALLASTS

FIG I TWO (2) LAMP RAPID START BALLAST

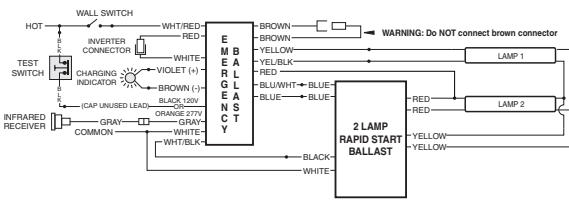

FIG K THREE (3) LAMP RAPID START BALLAST

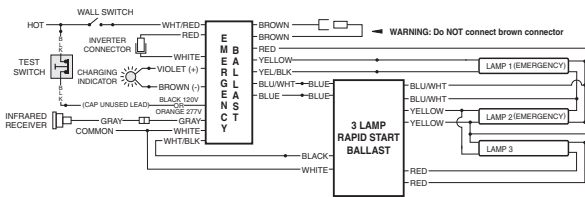

FIG M FOUR (4) LAMP RAPID START BALLAST

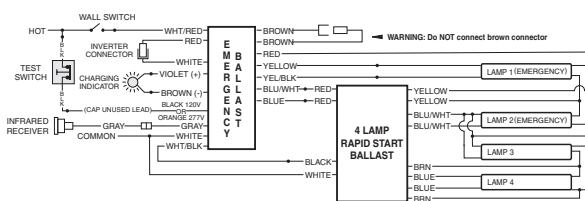
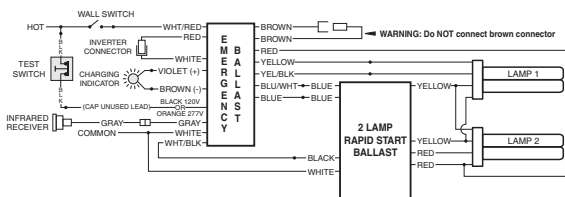

FIG O TWO (2) LAMP RAPID START BALLAST FOR 4-PIN COMPACT LAMPS



INSTANT START AC BALLASTS

FIG J TWO (2) LAMP INSTANT START BALLAST

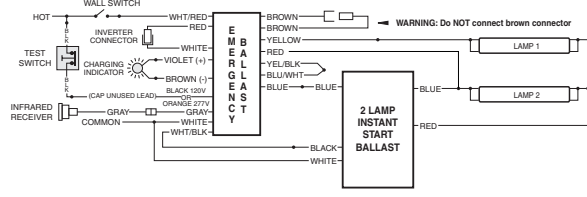

FIG L THREE (3) LAMP INSTANT START BALLAST

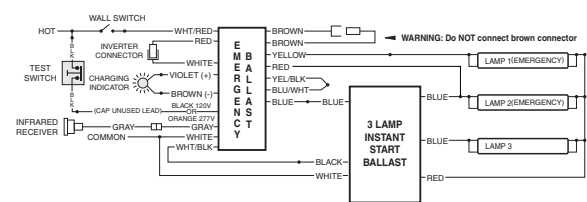
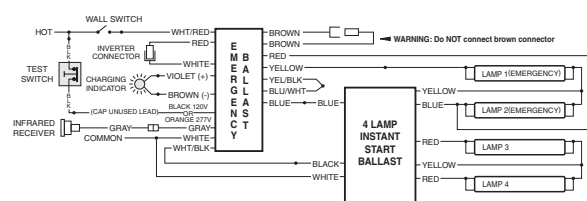

FIG N FOUR (4) LAMP INSTANT START BALLAST



WIRING DIAGRAM for EMERGENCY-ONLY fixtures

FIG P ONE (1) LAMP WITHOUT AC BALLAST (17 - 215 W)

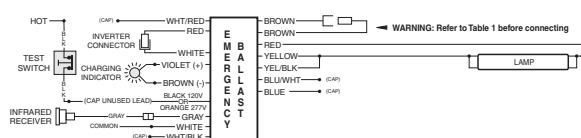
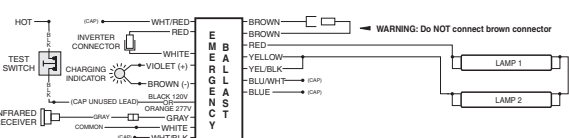

FIG Q TWO (2) LAMPS WITHOUT AC BALLAST (17 - 40 W)



NOTE: Installation of B30RCT Remote Control Testing fluorescent emergency ballast is different from standard Bodine models. The emergency ballast must interrupt the switched or unswitched hot lead feeding the AC ballast. Before beginning installation, consult these wiring diagrams.