



ARCTIC175PLS & ARCTIC400PLS 120V, 208V, 240V, or 277V



HIGH INTENSITY DISCHARGE
BACKUP BALLAST



FOR USE WITH PULSE-START LAMPS AND COMPATIBLE MAGNETIC BALLASTS*

INSTALLATION INSTRUCTIONS

! IMPORTANT SAFEGUARDS !

WHEN USING ELECTRICAL EQUIPMENT, BASIC SAFETY PRECAUTIONS SHOULD ALWAYS BE FOLLOWED, INCLUDING THE FOLLOWING:

READ AND FOLLOW ALL SAFETY INSTRUCTIONS

1. To prevent high voltage from being present on red output leads prior to installation, inverter connector must be open. Join inverter connector after the backup ballast has been installed and before the AC power is supplied.
2. The 175 W products are only for use with one 100 W to 175 W pulse-start metal halide lamp that requires no more than a single lamp holder and is operated in conjunction with a compatible magnetic AC ballast.*
3. The 400 W products are only for use with one 200 W to 400 W pulse-start metal halide lamp that requires no more than a single lamp holder and is operated in conjunction with a compatible magnetic AC ballast.*
4. Make sure all connections are in accordance with the National Electrical Code and any local regulations.
5. To reduce the risk of electric shock, disconnect both normal and auxiliary power supplies and inverter connector of the backup ballast before servicing.
6. This backup ballast is for factory or field installation.
7. An AC power source (120, 208, 240, or 277 VAC, 50/60 Hz, model dependent) ahead of any wall switch is required to provide battery charging current. See Unit Label for voltage requirements.
8. Do not install near gas or electric heaters.
9. This product is for use with indoor or damp locations where ambient temperature is -40°C to 55°C. Not suitable for wet or hazardous locations.
10. The battery module is field replaceable. Contact manufacturer for information on replacements. Use caution when replacing the battery module. Dispose of battery properly. Do not incinerate.
11. The use of accessory equipment not recommended by the manufacturer may cause an unsafe condition.
12. Do not use this product for other than intended use.
13. Servicing should be performed by qualified service personnel.
14. The minimum recommended installation temperature is 0°C.

*Compatible pulse-start magnetic ballasts: reactor style (R); high-reactance autotransformer (HX); constant-wattage autotransformer (CWA) - referenced throughout these Installation Instructions.

SAVE THESE INSTRUCTIONS



**THIS PRODUCT CONTAINS A RECHARGEABLE NICKEL-CADMIUM BATTERY.
THE BATTERY MUST BE RECYCLED OR DISPOSED OF PROPERLY.**

11/18/10

© Philips Emergency Lighting

A Division of Philips Electronics North America Corporation

Illustration 1

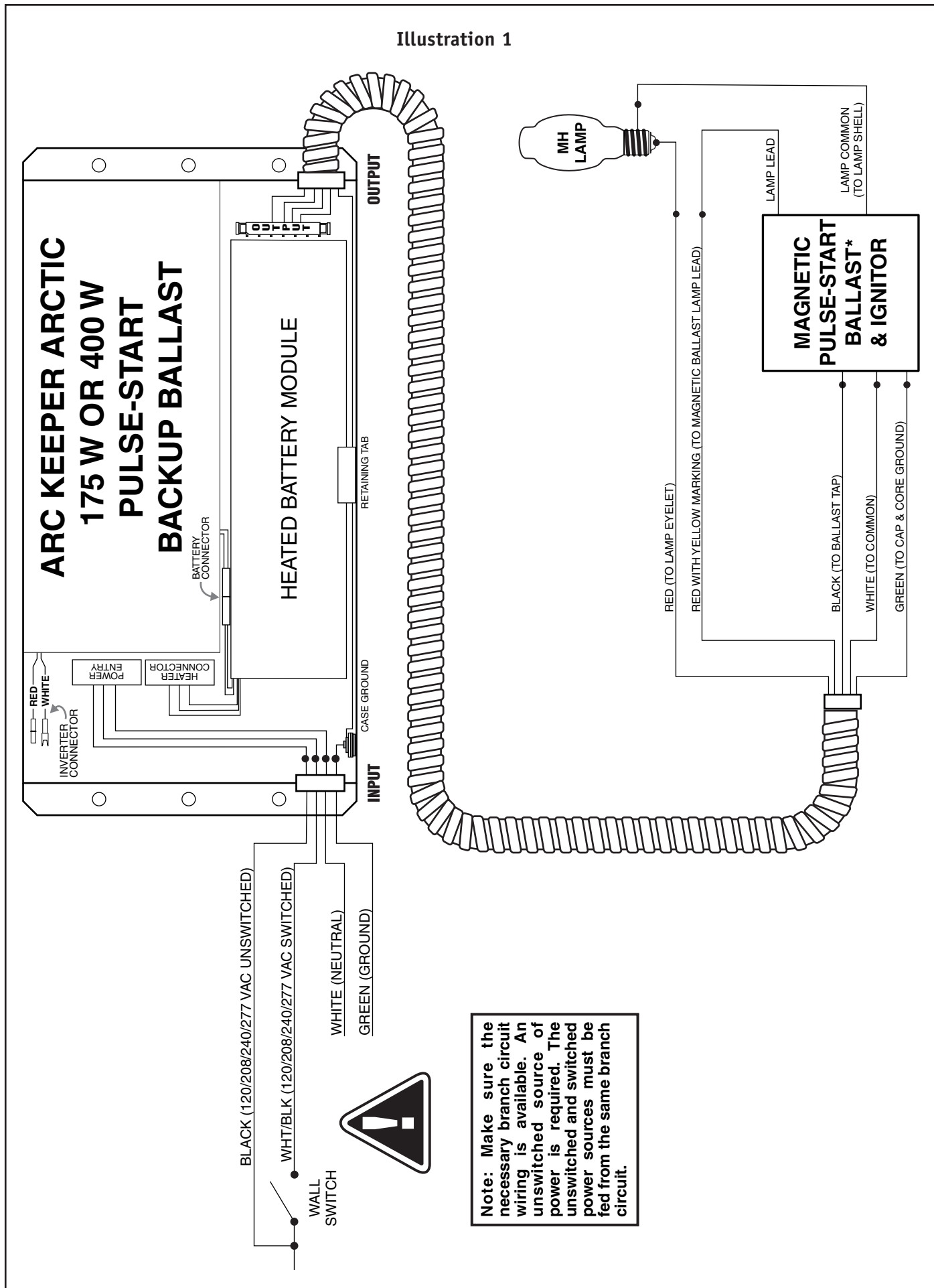

INSTALLATION

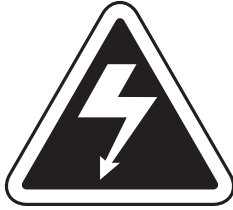

WARNING: TO PREVENT HIGH VOLTAGE FROM BEING PRESENT ON RED OUTPUT LEADS PRIOR TO INSTALLATION, INVERTER CONNECTOR MUST BE OPEN. JOIN INVERTER CONNECTOR AFTER INSTALLATION IS COMPLETE AND BEFORE AC POWER IS SUPPLIED.

NOTE: Make sure that the necessary branch circuit wiring is available. An unswitched source of power is required. The unswitched and switched power source must be fed from the same branch circuit.

INSTALLING THE BACKUP BALLAST

- > The backup ballast will be located between the AC power sources and the magnetic ballast* as shown in Illustration 1.
- > **NOTE:** The backup ballast may be installed in close proximity to the fixture or remote from the fixture. The maximum remote distance is one-half the maximum remote distance specified by the magnetic ballast manufacturer and is limited by the specific ignitor used. Contact the factory for more information.
- > The AC power is fed to the backup ballast.
- > The magnetic ballast* receives AC power from the output side of the backup ballast. The magnetic ballast* and backup ballast supply power to the metal halide lamp. Identify the output side of the backup ballast by the presence of the red leads.

STEP 1 ► DISCONNECT AC POWER FROM FIXTURE

- > Disconnect power leads from the magnetic ballast.*
- > Select a suitable location for the backup ballast and install such that its output leads reach the input leads of the magnetic ballast* and the lamp leads.
- > See Illustrations 2, 3, and 4 for typical installations and select appropriate mounting method.

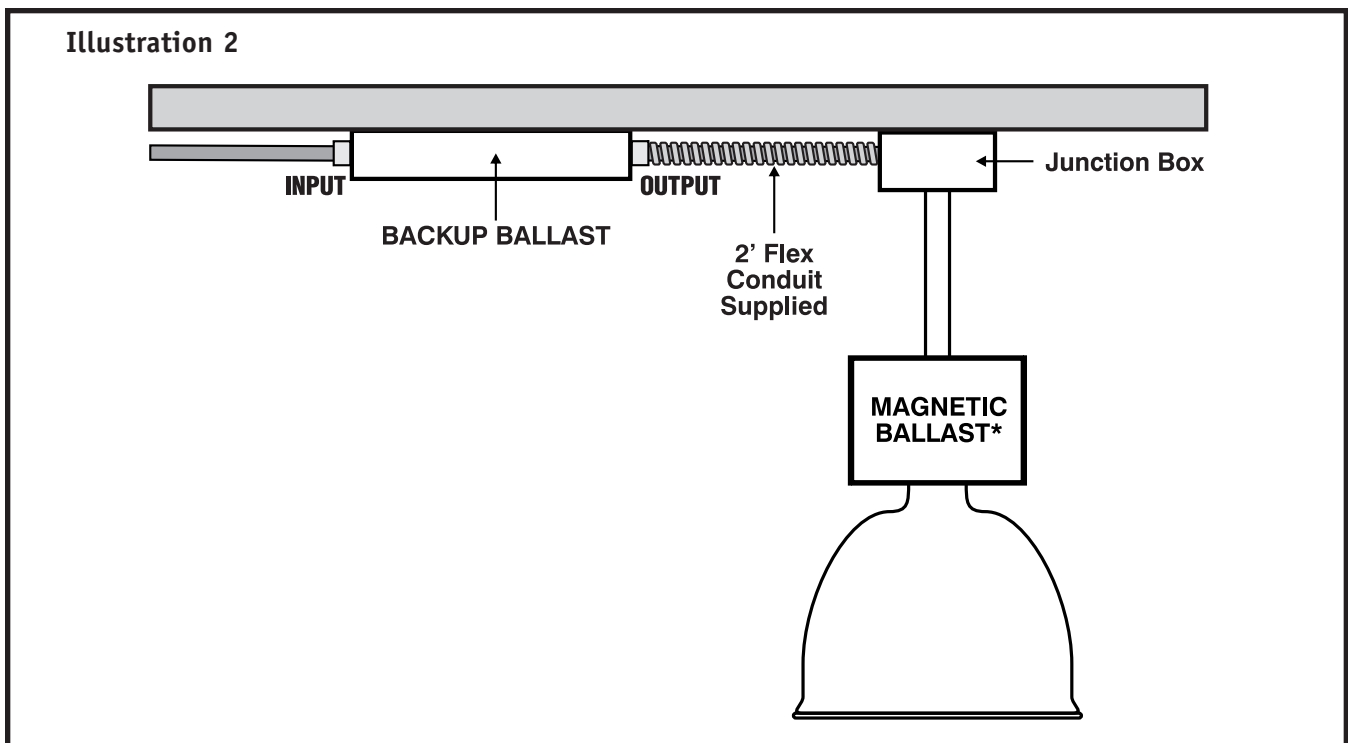

INSTALLATION

Illustration 3

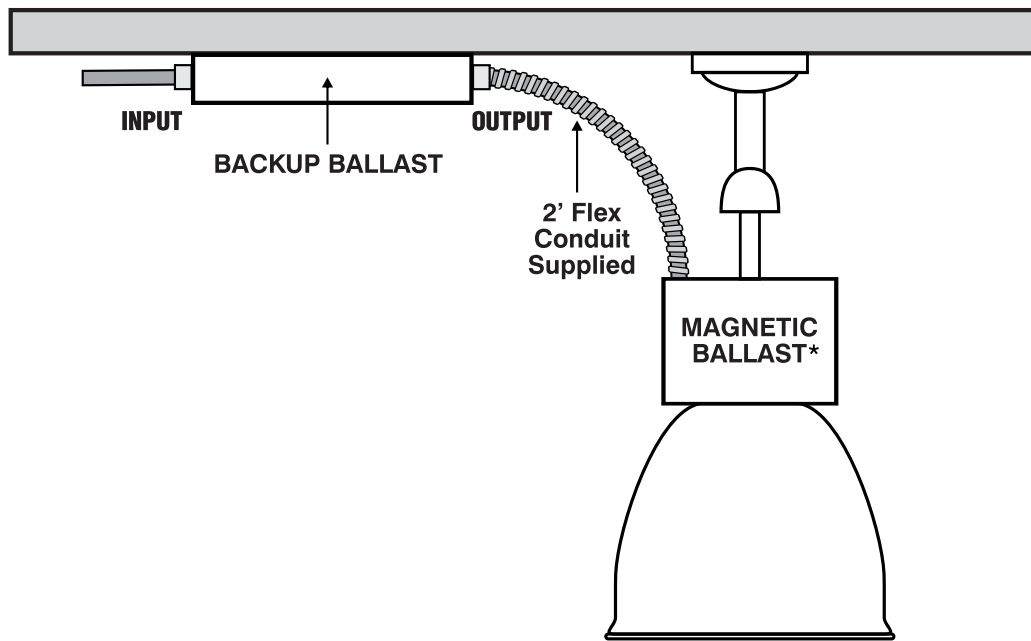
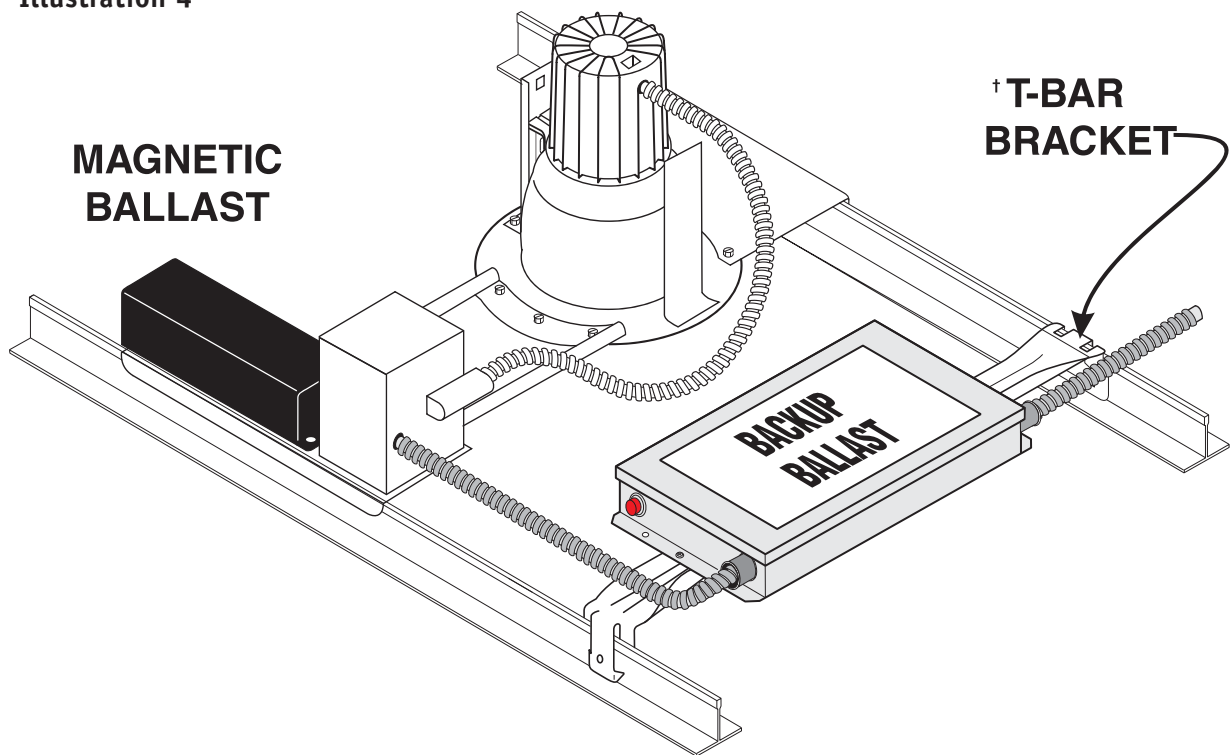

Illustration 4



† The T-BAR mounting bracket assembly is sold separately and is available from the factory as an accessory kit (T-BAR-MB). Call your local distributor or the factory for complete information.

INSTALLATION

STEP 2 ► CONNECT THE BACKUP BALLAST TO THE PROPER LINE VOLTAGE

- > Remove the lid from the backup ballast to expose the input wiring area, the input power leads, the ground lead, the battery module, and the inverter connector (see Illustrations 1 and 5).
- > Verify that the inverter connector (red and white) is disconnected. Note that the unswitched hot connects to the black backup ballast input lead. The switched hot connects to the backup ballast white/black input lead. Depending on the model, the line voltage will be either 120, 208, 240, or 277 VAC.

Illustration 5

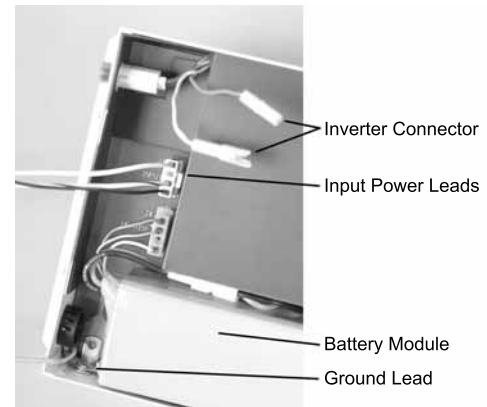

STEP 3 ► WIRING THE BACKUP BALLAST

- > Use the wiring diagram found in Illustration 1 as reference.
- > Connect the AC power source leads to the input of the backup ballast.
- > Connect the output leads of backup ballast to the magnetic ballast* and the lamp leads. The "lamp common" lead of the magnetic ballast* connects to the lamp shell as normal. The "lamp" lead of the magnetic ballast* that normally connects to the lamp eyelet will instead connect to the "red" output lead of the backup ballast with the yellow marking. The other "red" output lead of the backup ballast connects to the lamp eyelet.
- > There are only two leads connecting to the lamp. One is the "red" backup ballast wire connecting to the lamp eyelet. The other is the "common" lead from the magnetic ballast* connecting to the lamp shell. Make sure all connections are in accordance with the National Electrical Code and any additional local regulations.
- > In a readily visible location, attach the label "CAUTION—This Unit Has More Than One Power Connection Point. To Reduce The Risk Of Electric Shock, Disconnect Both The Branch Circuit-Breakers Or Fuses And DC Power Supply (Backup Ballast Inverter Connector) Before Servicing."

STEP 4 ► JOIN THE INVERTER CONNECTOR & APPLY POWER

- > After installation is complete, join the inverter connector (see Illustration 6). Replace the lid and apply AC power.
- > A short-term discharge test may be conducted after the backup ballast has been charging for 5 hours. Before performing any test, make sure that the magnetic ballast* has operated the lamp for at least 5 minutes. A short-term discharge test is conducted by momentarily disconnecting the circuit breaker(s) so both switched and unswitched AC power are removed for no more than 20 seconds.
- > After reapplying AC power, lamps protected with the backup ballast will continue to operate normally. Lamps NOT protected with the backup ballast will have extinguished.

Illustration 6

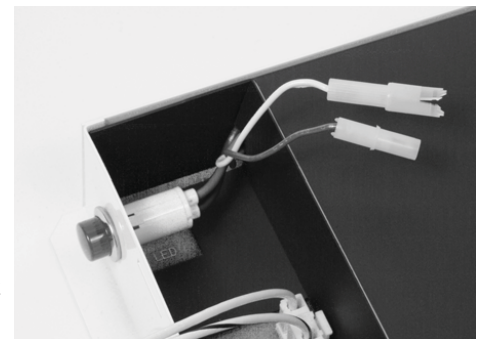

OPERATION

The backup ballast is a battery operated inverter-ballast that catches and maintains the arc in a pulse-start metal halide lamp during sags, interruptions, or failure of AC power for up to two minutes. The backup ballast will apply high frequency power directly to the lamp to supplement the low frequency 50/60 Hz power normally supplied to the lamp by the compatible magnetic ballast.* The backup ballast may be used with or without an auxiliary generator. If not used with an auxiliary generator, the backup ballast will serve to support and keep the lamp arc from extinguishing during power line interruptions for up to 2 minutes. If used with an auxiliary generator, the backup ballast's two-minute time limit allows more than ample time for an auxiliary generator to engage and support the metal halide lamp for emergency lighting purposes. See Illustration 7 for typical installation of the backup ballast when used with an auxiliary generator. Upon initial installation, or after a deep discharge of the battery, the backup ballast will need to be recharged before it can be expected to maintain the lamp arc for any significant length of time. The backup ballast should be allowed to recharge for a full 24 hours to ensure maximum battery capacity.

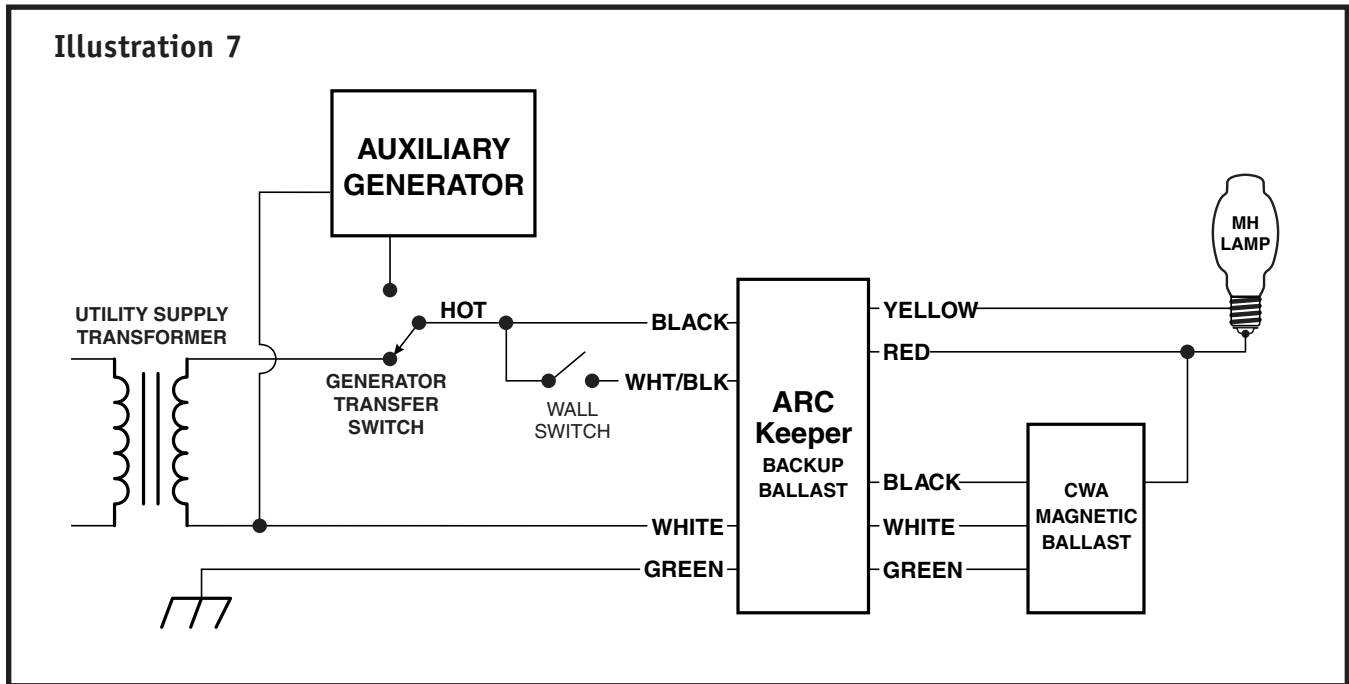

During day-to-day normal operation, the backup ballast will not try to maintain the lamp arc immediately when the lamp is first turned on; rather, there will be a 5-minute delay before backup ballast will attempt to "catch" the arc. This delay allows the lamp to warm-up each time it is turned on from a cold start. If the wall switch is switched from the "on" to the "off" position, in order to turn the lamp off, the backup ballast will initially catch the lamp arc. After a short delay the backup ballast will recognize that the switched power has been removed and that the unswitched power remains. The backup ballast will then release control of the lamp arc, allow the lamp to turn off as intended and return to the battery-charging mode. If the breaker is switched off, such that both the switched and unswitched power are removed, the backup ballast will react as it would for an AC power failure and maintain the lamp arc for up to 2 minutes before the arc is released.

MAINTENANCE

Although no routine maintenance is required to keep the backup ballast functional, it should be checked periodically to ensure that it is working. Perform a short-term discharge test once every 30 days.

If the battery module should need replacing, order the module appropriate for the rated line voltage as follows: PRT00090 for 120 VAC, PRT00091 for 208 VAC, PRT00092 for 240 VAC, or PRT00093 for 277 VAC.

! REFER ANY SERVICING INDICATED BY THESE CHECKS TO QUALIFIED PERSONNEL !